

## MODELS 7225AC, 7425AC LINE-POWERED AC BRUSHLESS SERVO AMPLIFIERS WITH $\pm 10V$ ANALOG U-V INPUTS

### FEATURES

- Complete line-powered servo amplifier for AC brushless motors with external sinusoidal commutation
- Off-the-line powered: 32~132VAC, 32~264VAC 50/60Hz, single-phase  
*No transformer required*
- Optically isolated power and signal stages
- Separate motor and signal Sub-D type connectors
- **FAIL-SAFE ENABLE INPUT**  
Ground or +5V active level selection
- **FAULT PROTECTIONS**  
Short-circuits  
output to output  
output to ground  
Over / under voltage  
Over temperature  
Self-reset or latch-off
- **CURRENT LIMIT**  
With no loss of Phasing and alert signal for control system
- 3kHz Bandwidth
- Wide load inductance range 0.4~ 40 mH.

### WORKS WITH POPULAR CONTROLLERS

- **ACS-Tech80** 5651A  
**ACS-Tech80** SPiiPlus series
- **PMD** MC1231A Chipset
- **Delta Tau** PMAC
- **MEI** DPS Series
- **Galil** DMC-1700

### THE OEM ADVANTAGE

- Internal header configures amplifier for plug and play operation
- Conservative design for high MTBF

MODEL	POWER	I-CONT (A)	I-PEAK (A)
7225AC	32~132VAC	10	20
7425AC	32~264VAC	10	20



### FEATURES

The 7xx5AC models are PWM servoamplifiers for AC brushless servomotors that are commutated externally by digital control systems that output two  $\pm 10V$  signals that represent the current command to the motor U and V windings. The amplifier then synthesizes the current command for the W winding.

Control cards take feedback from an encoder on the motor and use various techniques to determine the rotor position. When this has been done, the controller is able to output two signals that correspond to the current in the U and V windings to produce torque in the motor. The amplifier synthesizes the W winding current from UV signals that are either 120 or 90 electrical degrees apart.

Amplifier adjustments with this system consist of inductance compensation, current limit, transconductance, and offset. Thereafter, the controller does all of the velocity and/or position control of the motor.

An internal 40-pin solderless socket lets the user configure the various gain and current limit settings to customize the amplifiers for a wide range of loads and applications. Header components permit compensation over a wide range of load inductance's to maximize bandwidth with different motors.

Current limiting is provided via an internal solderless header socket or by an external resistance or voltage applied to the signal connector.

The /Enable input active logic-level is switch-selectable to ground or +5V to interface with all types of control cards. Fail-safe operation in either polarity results from an internal jumper that selects the default input level and input resistor pull-up or pull-down connections so that the amplifier shuts down with no input.

MOSFET (7225AC) and IGBT (7425AC) output stages deliver four-quadrant power for bi-directional acceleration and deceleration of motors. For high-inertia loads, an external regenerative energy dissipater is available.

All models are protected against output short circuits (output to output and output to ground) and heatplate overtemperature. With the /Reset input open the amplifier will latch off until powered-down or the /Reset input is toggled. The amplifier will reset itself automatically from faults if the /Reset input is wired to GND.



## MODELS 7225AC, 7425AC LINE-POWERED AC BRUSHLESS SERVO AMPLIFIERS WITH +/-10V ANALOG U-V INPUTS

### TECHNICAL SPECIFICATIONS

MODEL	7225AC	7425AC
<b>OUTPUT POWER</b>		
Peak power	20 A @ 110V	20 A @ 205V
Peak time	2 sec at peak power independent of polarity reversal	
Continuous power	10 A @ 130V	10 A @ 250V
<b>OUTPUT VOLTAGE</b>		
On-resistance (Ro, ohms)	0.2	0.15
Max PWM Peak Output Voltage	$\pm V_{out} = (VAC \times 1.41 \cdot 2) \times (0.97) - (R_o) \times (I_o)$	
<b>INPUT POWER</b>		
Mains voltage	32~132VAC, 47~63Hz	32~264VAC, 47~63Hz
Mains current @ continuous output rating	16 A	16 A
Inrush current on startup	19 A	37 A
External mains fuse rating	20 A/125V	20 A/250V
<b>LOAD INDUCTANCE</b>		
Minimum inductance	400 $\mu$ H.	400 $\mu$ H.
Maximum inductance	No maximum. See chart of load inductance values. Bandwidth varies with inductance and header parts.	
<b>BANDWIDTH</b>	Small signal -3dB @ 3kHz with minimum load at nominal supply voltage. Varies with load inductance and header values	
<b>PWM OUTPUTS</b>		
PWM frequency	25kHz	
Modulation	Carrier-cancellation, 50% duty cycle at 0V output	
<b>REFERENCE INPUT</b>	Differential, 94k $\Omega$ max. to 47k $\Omega$ min. between inputs, $\pm$ 20V maximum	
<b>POTENTIOMETERS</b>	U Ref Fine Gain (R1) Default = Center	CCW attenuates U Reference.
	V Ref Fine Gain (R2) Default = Center	CCW attenuates V Reference.
	(Internal)	
	U phase current Zero (R7)	Adjusts U output current to zero with U and V inputs = 0V.
	V phase current Zero (R6)	Adjusts V output current to zero with U and V inputs = 0V.
<b>DIPSWITCH</b>		
S1	/Enable input active polarity. OFF (default): Gnd enables amplifier, open or +5V inhibits. ON: Gnd inhibits, open enables	
<b>UV PHASE SELECTION</b>	Internal jumper JP1-A selects UV phase of 120° or 90° (Default = 120°)	
<b>LOGIC INPUTS</b>		
/Enable	Default = GND	GND enables amplifier, open or >2.5V inhibits with S1 OFF. If S1 ON then GND inhibits. See following section on fail-safe operation for JP1-B settings.
/Reset	Default = Open	Response time is 1 ms from enable active to amplifier output ON.
/Motemp	Default = GND	GND resets latching fault condition, ground for self-reset every 50 ms.
Input resistance		Motor temperature sensor. Typically normally closed bimetal sensor. Open = overtemp
Logic threshold voltage		10k $\Omega$ to +5V, R-C filters on inputs
Input voltage range		2.5V (Schmitt trigger inputs with hysteresis, 74HC14) 0V to +32VDC
<b>FAIL-SAFE ENABLE INPUT</b>		
Internal jumper JP1-B selects +5V or GND connection for input pull-up resistors to /Enable input only so that amplifier will default to <i>disabled</i> condition if inputs are open-circuit, or wires are broken. (See Applications section for details)		
<b>LOGIC OUTPUTS</b>		
/Normal		LO (current sinking) when status LED is green; HI when LED is red or blinking red / green.
HI output voltage		+5V (no load). Output is N-channel MOSFET drain terminal with 10k $\Omega$ pull-up resistor to +5V
LO output voltage		On resistance Ro = 5 $\Omega$ . Max sink current of 250 mA. max off-voltage = 50VDC
Amp OK		Buss volts OK AND NOT (output short OR overtemp)
/CLIMIT		N-channel opto-isolator is ON when amp is OK. ON current 4 mA min. Max voltage 32 VDC
HI output voltage		HI when amplifier is not current limiting; LO when current is limit is reached.
LO output voltage		+5V (No load). Output is LM339 open collector with 10k $\Omega$ pull-up resistor to +5V Max sink current of 15 mA, max off voltage = 36VDC
<b>STATUS LED</b>		
Bicolor LED changes color and flashes to indicate amplifier operating status		
Green = Normal	Amplifier enabled AND Amp OK (see above)	
Blinking green = Ready	Amplifier OK, will run when enabled	
Red = Fault, non-latching	Over or under-voltage condition or motor overtemp; Amplifier recovers when voltage or temp. is in normal range.	
Blinking red = Latching Fault	Output overcurrent (short circuit) or amp. overtemp condition. Ground /Reset or power amp. off/on to clear condition	
<b>CURRENT LIMIT INPUT</b>		
Current limit	0-5V controls current limiting (See application section for details)	
<b>MONITOR OUTPUTS</b>		
Current Monitor U	Motor winding current in U phase: $\pm$ 10V @ $\pm$ 20 A or 2 A/V (1k $\Omega$ , 33nF R-C filter)	
Current Monitor V	Motor winding current in V phase: $\pm$ 10V @ $\pm$ 20 A or 2 A/V (1k $\Omega$ , 33nF R-C filter)	
<b>DC POWER OUTPUTS</b>		
+5V @ 200 mA max (J3-23)		
+10VDC @ 5 mA (J3-24)		
-10VDC @ 5 mA (J3-25)		
Note: maximum power from all DC outputs not to exceed 1.4W		

## MODELS 7225AC, 7425AC LINE-POWERED AC BRUSHLESS SERVO AMPLIFIERS WITH +/-10V ANALOG U-V INPUTS

### PROTECTIVE FEATURES

<p>Short circuit (output to output, output to ground) OverTemperature</p> <p>Undervoltage Overvoltage</p> <p>Current-limiting</p>	<p>Latches unit OFF (Power off/on, or ground at /Reset input resets)</p> <p>Latches unit OFF at 70°C on heatplate (Power off/on, or ground at /Reset input resets)</p> <p>Wire /Reset input to ground for automatic reset after latching fault</p> <p>Shutdown at internal DC buss &lt; 45VDC</p> <p>Shutdown at internal DC buss &gt; 195VDC (Model 7225AC), or internal DC buss &gt; 390VDC (Model 7425AC) (Amplifier operation resumes when internal DC buss is NOT Undervoltage or NOT Overvoltage )</p> <p>Output current set by header component or external voltage or resistance</p> <p>Current will fold-back to continuous rated current (10 A) after 2s maximum at 20 A</p> <p>Relative amplitude of U/V/W phase currents maintained for no loss of commutation</p>
---	--

### AMPLIFIER DISSIPATION

Watts minimum	17W (Model 7225AC)	7W (Model 7425AC)
Watts @ continuous current	60W (Model 7225AC)	61W (Model 7425AC)

### THERMAL REQUIREMENTS

Storage temperature range	-30°C to +85°C
Operating temperature range	0° to 70°C baseplate temperature
Thermal resistance (heatplate to ambient):	No heatsink or fan: 0.92 deg. C/W; no heatsink with fan: 0.51 deg. C/W With heatsink, no fan: 0.6 deg. C/W; with heatsink and fan: 0.23 deg. C/W

### MECHANICAL

Size	7.50 x 6.94 x 2.72 in. (190 x 174 x 69 mm) without optional heatsink 7.50 x 6.94 x 4.72 in. (190 x 174 x 120 mm) with optional heatsink
Weight	3.71 lbs. (1.69 kg) without optional heatsink. Add 3.2 lbs. (1.47 kg) for heatsink.

### CONNECTORS

J1: Power & motor	9-position terminal strip
J2: Motor temperature	15-position female Sub-D type. #4-40 standoffs for cable shell lock screws
J3: Signal	25-position female Sub-D type. #4-40 standoffs for cable shell lock screws
	Connector shells are connected to amplifier chassis for grounding/shielding

## PANEL LAYOUT

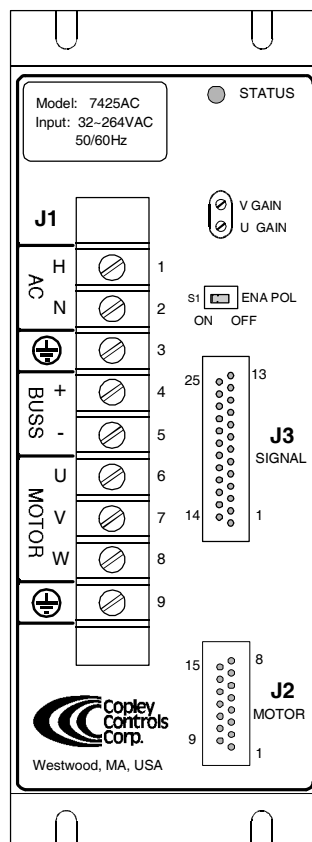

**MODELS 7225AC, 7425AC**  
**LINE-POWERED AC BRUSHLESS SERVO AMPLIFIERS**  
**WITH +/-10V ANALOG U-V INPUTS**

**TYPICAL AMPLIFIER CONNECTIONS**

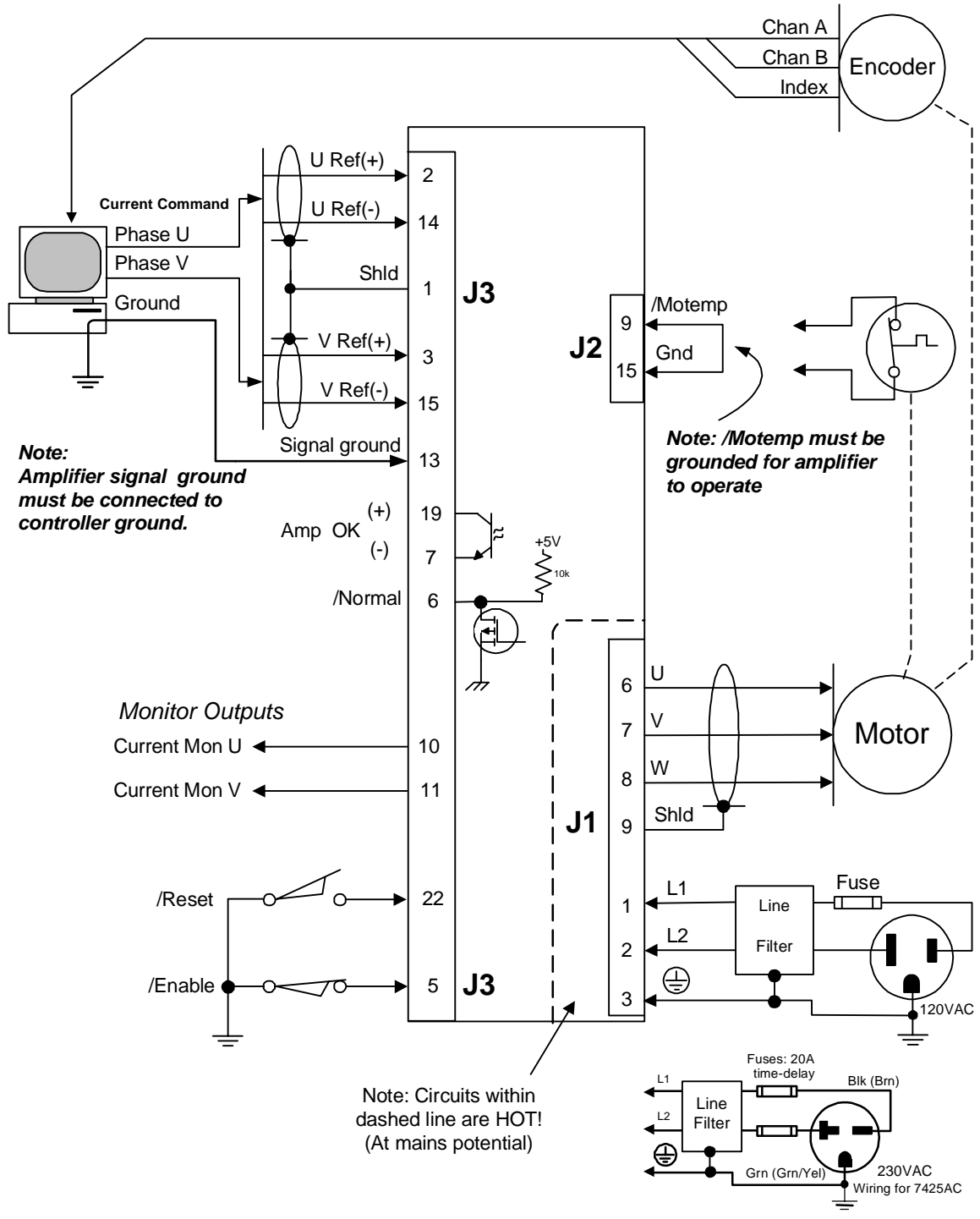

## MODELS 7225AC, 7425AC LINE-POWERED AC BRUSHLESS SERVO AMPLIFIERS WITH +/-10V ANALOG U-V INPUTS

### CONNECTORS

#### J1 POWER AND MOTOR WINDING CONNECTIONS

Connector type: Barrier-block. Screw-terminal connections. #6-32 locking screws with cable clamps.

PIN	SIGNAL	FUNCTION
1	L1	AC Power Input Hot (black or brown wire from AC mains)
2	L2	AC Power Input Neutral (white or blue wire from AC mains)
3	GND	Chassis safety ground (green or green/yel wire from AC mains)
4	Buss (+)	Positive terminal of internal DC power supply
5	Buss (-)	Negative terminal of internal DC power supply
6	Motor U	Amplifier output to "U" winding of motor
7	Motor V	Amplifier output to "V" winding of motor
8	Motor W	Amplifier output to "W" winding of motor
9	GND	Chassis safety ground. Also for cable shield of motor cable.

#### J2 MOTOR TEMPERATURE CONNECTIONS

Connector type: Female Sub-D, 15 position, #4-40 locking standoffs

PIN	SIGNAL	FUNCTION
1	Safety GND	Chassis ground. Use to ground cable shield. Not connected to internal signal ground.
2	N.C.	
3	N.C.	
4	N.C.	
5	N.C.	
6	N.C.	
7	N.C.	
8	N.C.	
9	Motemp	<b>Note: Must be grounded for amplifier to operate (Connect to J2-10,12,14, or 15)</b>
10	0V	Signal ground
11	N.C.	
12	0V	Signal ground.
13	N.C.	
14	0V	Signal ground.
15	0V	Signal ground.

#### J3 SIGNAL CONNECTIONS

Connector type: Female Sub-D, 25-position, #4-40 locking standoffs

PIN	SIGNAL	FUNCTION	PIN	SIGNAL	FUNCTION
1	Safety GND (Case)	Chassis ground. Use to ground cable shield. Not connected to internal signal ground (J3-12, 13,16).			
2	U Ref (+)	Positive terminal of differential +/-10V analog command input	14	U Ref (-)	Negative terminal of differential +/-10V analog command input
3	V Ref (+)	Positive terminal of differential +/-10V analog command input	15	V Ref (-)	Negative terminal of differential +/-10V analog command input
4	N.C.		16	0V.	Signal ground.
5	/Enable input	Amplifier enable	17	N.C.	
6	/Normal output	Mosfet output amp status	18	N.C.	
7	Amp OK (-) output	Opto-isolator emitter (NPN)	19	Amp OK (+) output	Opto-isolator collector (NPN)
8	N.C.		20	Ext. I-limit	External setting of curr. limit
9	/CLIMIT	Current limit status	21	N.C.	
10	Current Monitor U	+/-10V @ +/-20 A	22	/Reset input	
11	Current Monitor V	+/-10V @ +/-20 A	23	+5V @ 200 mA.	Auxiliary DC power for user devices
12	0V.	Signal ground.	24	+10V @ 5 mA	Auxiliary DC power
13	0V.	Signal ground <b>must be connected to the controller ground</b>	25	-10V @ 5 mA	Auxiliary DC power

## MODELS 7225AC, 7425AC LINE-POWERED AC BRUSHLESS SERVO AMPLIFIERS WITH +/-10V ANALOG U-V INPUTS

### FUNCTIONAL DIAGRAM

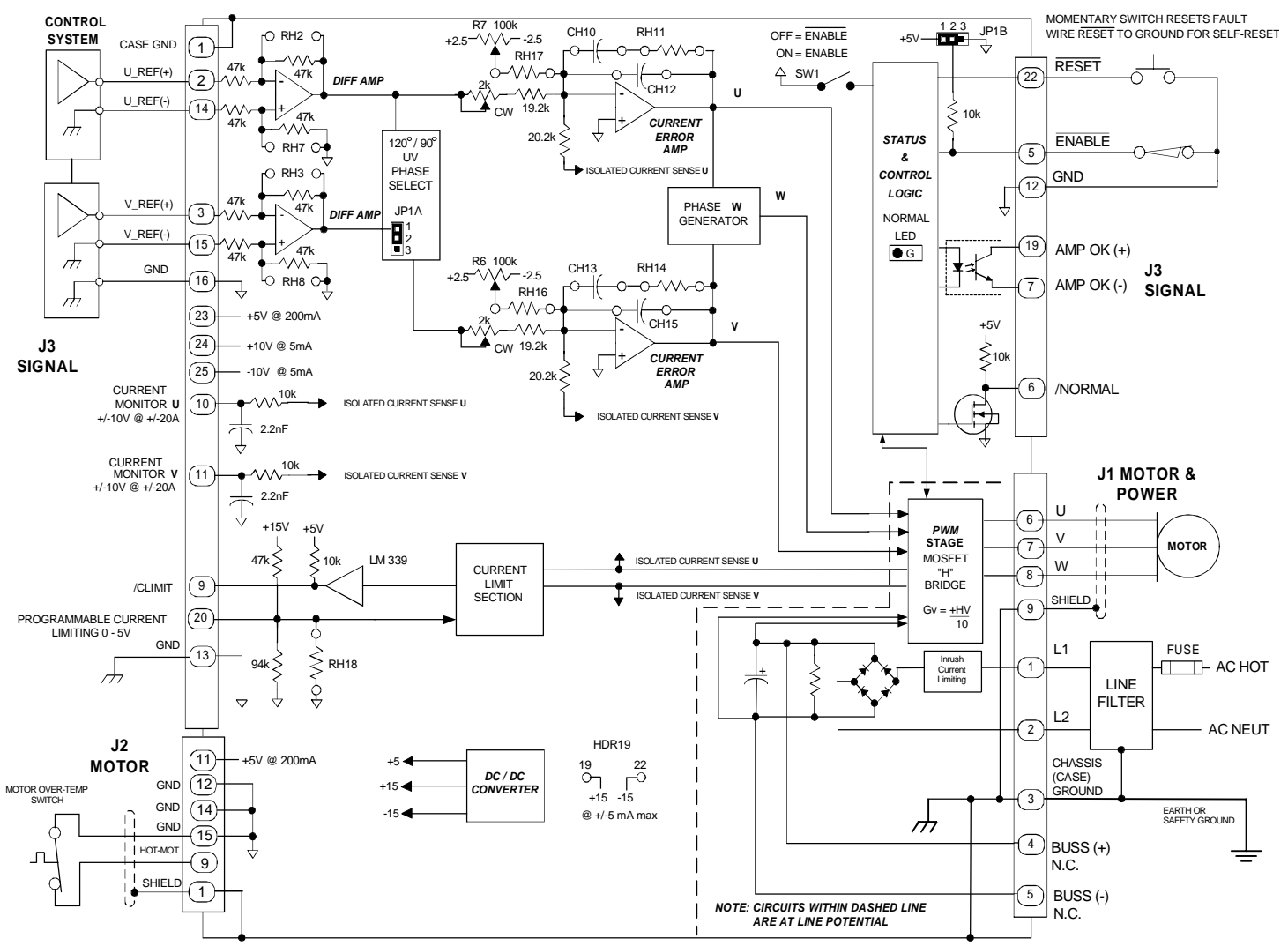

### SIGNAL BOARD AND HEADER SOCKET LAYOUT

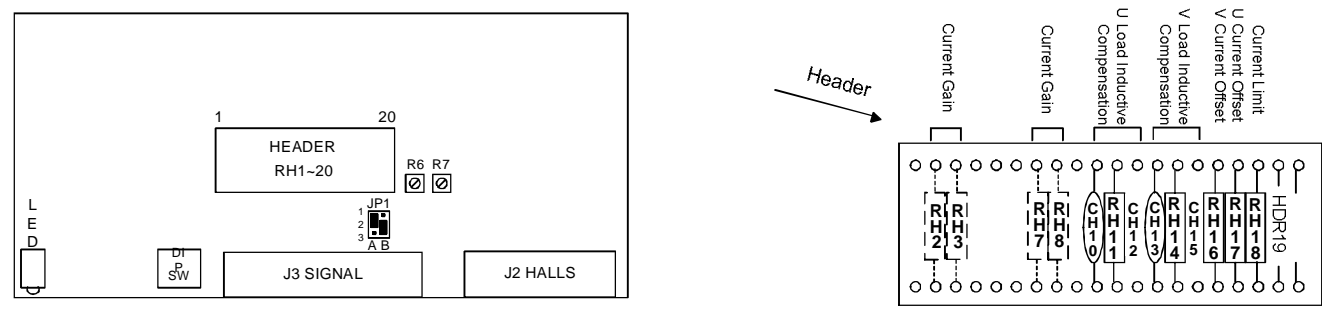

The header socket holds components that determine the amplifier performance such as inductance compensation, offset scaling, and peak current limit. Components are named RHn, CHn as Resistor Header n, Capacitor Header n, etc. See applications section for details.

## MODELS 7225AC, 7425AC LINE-POWERED AC BRUSHLESS SERVO AMPLIFIERS WITH +/-10V ANALOG U-V INPUTS

### APPLICATION INFORMATION

#### EXTERNAL COMMUTATION OVERVIEW

The model 7XX5AC amplifiers are designed to work with controllers that perform external commutation to drive AC brushless motors. Lower torque ripple can be obtained by sinusoidal commutation of the three-phase motor than can be obtained by trapezoidal commutation. The figure below shows a typical external commutation configuration using an encoder for determining position. The controller uses two DAC outputs, the U and V Phase, to drive the U and V reference inputs on the amplifier. The amplifier then generates W Phase and delivers power to all three motor windings simultaneously.

The encoder data is processed by the controller, to generate the sinusoidal waveform signals, which are delivered to the amplifier. These waveforms are typically 120° phase separated, a jumper in the amplifier can be moved for 90° phase separation. The controller will perform a phase initialization routine for proper commutation. Improved phase initialization can be achieved by using Hall sensors for determining initial position.

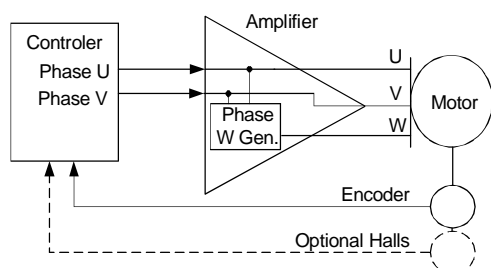

#### AMPLIFIER WIRING & CABLING

Power supply and motor connections should be made with wire that has a rating to support the amplifiers continuous current. AWG 14 wire will support all amplifiers in this series. To minimize noise radiation from the motor and power cabling, wires should be twisted and shielded. Motor sensor signals are often routed near the motor phase winding cables. To minimize coupling of PWM noise, sensor signal wiring should be multiple-conductor-shielded cable.

#### GROUNDING AND ISOLATION

The signal board is fully isolated from the power section in this series of amplifiers. For proper operation, **connect the signal ground J3-13 to the controller ground.**

**For safety, it is important that J1-3 be connected to earth ground,** typically through the power cable.

The connections on the power board, such as the motor phase, are at line potential.

#### SETUP FOR THE MOTOR

The motor windings and encoder are to be connected in accordance with the control card setup.

#### MOTOR INDUCTANCE COMPENSATION

Header components control the amplifier compensation for different motors. These set the gain in the current error amplifier to give the best response for different winding inductance. There are two current-control loops in this series of amplifiers, both must have the same values in the header. The tables below give values for the header parts for the two models. The default values for RH11 and RH14 are indicated below in bold & italic. If the inductance of your motor is less than 1/2 of the value shown in the table, use the values from the next *lower* inductance range. Ex., for a 4 mH motor, use the values from the 3 mH row (1/2 of 10mH is 5mH, which is greater than 4mH, so the value from the next *lower* row, 3mH, is used).

**For all tables: CH12 & CH15 are <out>**

##### Model 7225AC @ 115VAC; CH10 & CH13 = 15nF

L (mH)	R11& RH14 (kΩ)
0.3	18
<b>1</b>	<b>39</b>
3	75
10	180
30	300

##### Model 7425AC @ 230VAC; CH10 & CH13 = 10nF

L (mH)	R11& RH14 (kΩ)
0.3	12.5
<b>1</b>	<b>24.9</b>
3	51
10	120
30	200

##### Model 7425AC @ 115VAC CH10 & CH13 = 10nF

L (mH)	R11& RH14 (kΩ)
0.3	18
1	39
3	75
10	180
30	300

If the default values do not give sufficient bandwidth, contact factory for a detailed tuning procedure.

## MODELS 7225AC, 7425AC LINE-POWERED AC BRUSHLESS SERVO AMPLIFIERS WITH +/-10V ANALOG U-V INPUTS

### /ENABLE INPUT ACTIVE LEVEL CONTROL

DIP switch S1, ENAB POL, controls active level of the amplifier enable input at J3-5. The *default* position is S1 OFF, this will make the /Enable input ground-active, >2.5V will disable the amplifier. With S1 ON, this will make the /Enable input disable amplifier if grounded, >2.5V will enable.



### ENABLE INPUT FAIL SAFE CONTROL

Jumper JP1-B, on the signal board, controls the /Enable input level control resistor. The figure below shows the function, with S1 OFF and JP1-B on pins 1-2 as the default condition. The /Enable input must be pulled LO to enable the amplifier, and if the input is open (disconnected or wire broken) the amplifier turns off as the input is pulled-up to +5V. This is called *fail-safe* because the amplifier must be connected, and the input actively driven to ground to turn the amplifier ON, otherwise it's OFF.

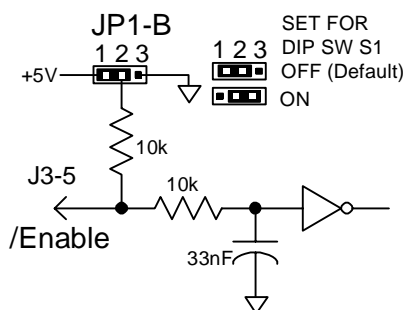

If an active HI fail-safe operation is desired, then turn S1 ON and move JP1-B to pin 2-3. Now the input is *pulled-down* to ground if it is disconnected, and must be actively pulled-up to >2.5V by the control system to enable the amplifier.

### U V PHASE ANGLE

Jumper JP1-A, on the signal board, sets the UV phase to either 120° or 90°. The default is 120°.

JP1-A

-  120 Degrees UV Phase (Default)
-  90 Degrees UV Phase

### MOTOR TEMPERATURE SENSOR

**The /MOTEMP (J2-9) line must be pulled to GND (J2-15) in order to enable the amplifier.** The figure below shows the function. A normally closed thermal switch can be connected to protect the motor from over temperature. When the switch opens the /MOTEMP line is pulled to +5V through a 10k resistor, disabling the amplifier.

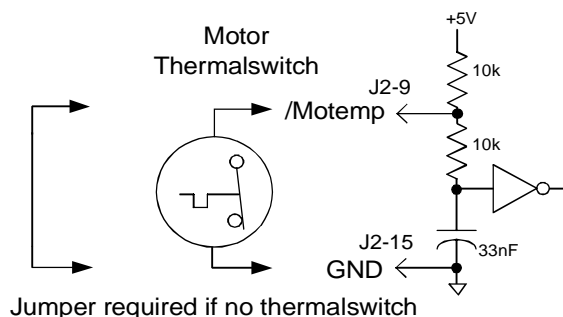

### REFERENCE INPUTS

The reference inputs are the command signals to the amplifier. There are two differential reference inputs U Ref (+), U Ref (-) and V Ref (+), V Ref (-) *Use all four reference wires.* Connect U Ref (-) and V Ref (-) to control system ground. Connect U Ref (+) and V Ref (+) to control system's separate ±10V outputs. This will reject noise between control system and amplifier grounds. Use twisted-pair cable to minimize noise pickup between amplifier and controller.

### U V PHASE CURRENT ZERO ADJUSTMENT BALANCE ADJUSTMENT RANGE

Control of the balance adjustment range can be made via internal components RH16 and RH17 on the header socket. The full-scale can be adjusted over a typical range of 500mA to 50mA. A good first approximation would be 5% of the motors continuous current rating. See below table, for selecting resistor values for RH16 and RH17. The default values are indicated in bold.

*U V zero adjust full-scale RH16 & RH17*

Offset full-scale mA	Rx (Ω)
500	200k
<b>400</b>	<b>250k</b>
300	330k
200	475k
100	1M
50	2.2M

These values are within 10%, typically. For greater accuracy, measure current monitor and select parts for exact full-scale value.



## MODELS 7225AC, 7425AC LINE-POWERED AC BRUSHLESS SERVO AMPLIFIERS WITH +/-10V ANALOG U-V INPUTS

### ZERO ADJUSTMENT

The current OFFSET potentiometers are factory set to zero current with zero input. The sum of the three currents U, V and W can be set to a high degree of resolution by using the current monitors. After connecting and tuning the motor, ground the U and V reference inputs, then adjust the offset potentiometer (see below table) while monitoring the appropriate current monitor U (J3-10) and V (J3-11) with respect to Ground (J3-13).

If the U and V currents are correctly set to zero then the W current will also be zero:  $I_w = -(I_u + I_v)$

POT	DEFAULT	DESCRIPTION
<b>U OFFSET</b> (R7 internal)	Center	U zero output current adjustment
<b>V OFFSET</b> (R6 internal)	Center	V zero output current adjustment

### TRANSCONDUCTANCE ADJUSTMENT OVERALL GAIN

The current gain or transconductance is the ratio of output current to input voltage. The transconductance should be set to provide a better use of the controllers output range, typically a +/-10V DAC. The gain can be set via RH2, RH3, RH7, and RH8, see below table. All resistor values must be the same. Use 1% tolerance for good CMRR (common mode rejection ratio).

It is recommended that the transconductance be set to limit the peak current delivered to the motor. Most applications require peak currents of two or three times the motors continuous current rating. Example: For a typical +/-10V DAC and a required 15 Amps peak, the transconductance should be set to 15 Amps / 10 Volt = 1.5 Amps / Volt.

The Gain (Amps / Volt) =  $2 * R_x \Omega / (47k\Omega + R_x \Omega)$ . The default gain is 2A/V with RH2, RH3, RH7, and RH8, resistors open or out of circuit. (Indicated in bold & italic in the table below).

Transconductance  $R_x = RH2, 3, 7 \text{ \& \, } 8$

Gain Amps/Volt	$R_x (\Omega)$
<b>2</b>	<b><i>OPEN</i></b>
1.5	140k
1	47k
0.5	15.6k

### GAIN FINE ADJUSTMENT

The REF GAIN potentiometers are factory set to give a matched transconductance of 2Amps/Volt, with RH2, RH3, RH7, and RH8, resistors open or out of circuit. The gain of both U and V channels can be fine-tuned to match. The range is about +/-5%. To fine adjust the transconductance, input a reference voltage, such as 1VDC, to the U Ref (+) (J3-2) and V Ref (+) (J3-3), Remembering to ground Ref (-) (J3-14, J3-15) at the source. Then while monitoring the appropriate current monitor, adjust the REF GAIN potentiometers to match.

POT	DEFAULT	DESCRIPTION
<b>U REF GAIN</b> (R1)	Center	U Fine gain control CW increases gain
<b>V REF GAIN</b> (R2)	Center	V Fine gain control CW increases gain

### CURRENT LIMIT

Control of the current limit can be made internally via component RH18 in the header socket, or externally via connector pin J3-20. See figure below.

A resistor can be connected between this pin and signal ground (J3-12, 13, or 16), or the pin can be driven by a voltage between 0 and +5VDC. Using this technique, the current limit can be controlled over a range of 100% to 50% of the peak command current, set by the transconductance.

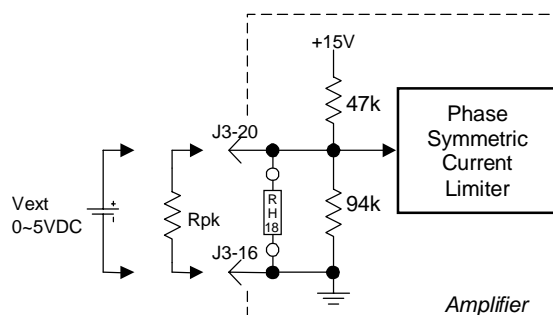

**CURRENT LIMIT (RH18)**  
Default values are in bold & italic.

I-limit	RH18	Vext
<b>10</b>	<b><i>31.6k</i></b>	<b>5</b>
8	16.9k	3.5
6	10.5k	2.5
4	5k	1.4
2	1.3k	0.4

These values are within 10%, typically. For greater accuracy, measure current monitor and select parts for exact limit value.

## MODELS 7225AC, 7425AC LINE-POWERED AC BRUSHLESS SERVO AMPLIFIERS WITH +/-10V ANALOG U-V INPUTS

### STATUS SIGNALS

#### CURRENT-LIMIT OUTPUT

This is an output signal which is HI (+5V) when the amplifier is not current limiting. As the current limiting starts to take effect the /CLIMIT output will go LO (0V).

This is very useful for a closed loop control system that expects the amplifier to be operating in a linear manner. Since, the /CLIMIT line transitions LO on the first detection of current limiting, the controller can be alerted to non-linear behavior immediately.

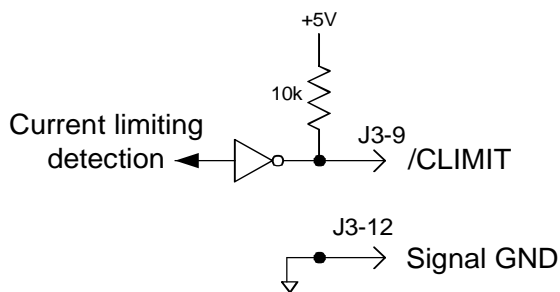

#### LED INDICATOR FUNCTIONS

Color and state of LED indicates amplifier operating conditions

LED COLOR	CONDITION	ACTION to ENABLE
Flashing Green	Ready (AMP OK)	Activate /ENABLE
Green	Normal	None
Red	Fault	Power, /MOTEMP (J2-9)
Flashing Red	Latching Fault	/Reset, Power OFF/ON

Ready = Amp OK AND NOT enabled  
 Normal = Amp OK AND enabled  
 Amp OK = Internal buss voltage is within limits AND NOT Fault

Fault = Over voltage, under voltage, or motor overtemp.  
 Latching Fault = Output short circuit or heatplate overtemperature. Amplifier 'latches' off and stays off until reset.

### /NORMAL OUTPUT SIGNAL

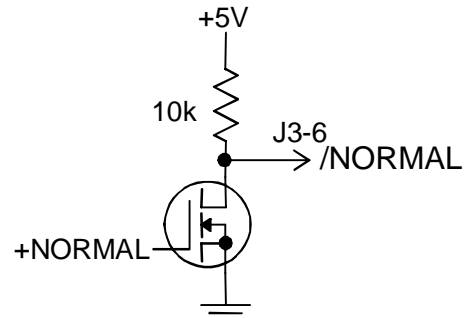

N-channel mosfet with 10k-ohm resistor connected to +5V. Maximum voltage: 50VDC. Maximum current 250 mA. On-resistance = 5 ohms.

Output is LO (mosfet ON) whenever amplifier is enabled and NORMAL (LED Green)  
 Output is HI (mosfet OFF) whenever amplifier is NOT enabled, or FAULT occurs.

### OPTO-ISOLATED NORMAL OUTPUT SIGNAL

This AMP OK signal indicates that the amplifier ready to run. It is completely optically isolated from the amplifier. The input of the optocoupler is driven by the amplifier logic circuits, and the output is a floating NPN transistor with both terminals brought to signal connector J3 as shown below.

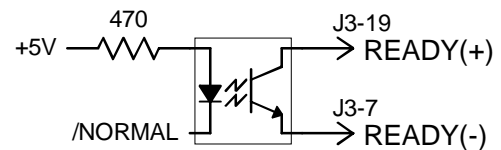

Maximum voltage = 32VDC. ON current = 4mA. minimum Output transistor ON voltage: 0.4 at 4mA

**MODELS 7225AC, 7425AC**  
**LINE-POWERED AC BRUSHLESS SERVO AMPLIFIERS**  
**WITH +/-10V ANALOG U-V INPUTS**

**INTERFACE DIAGRAM**

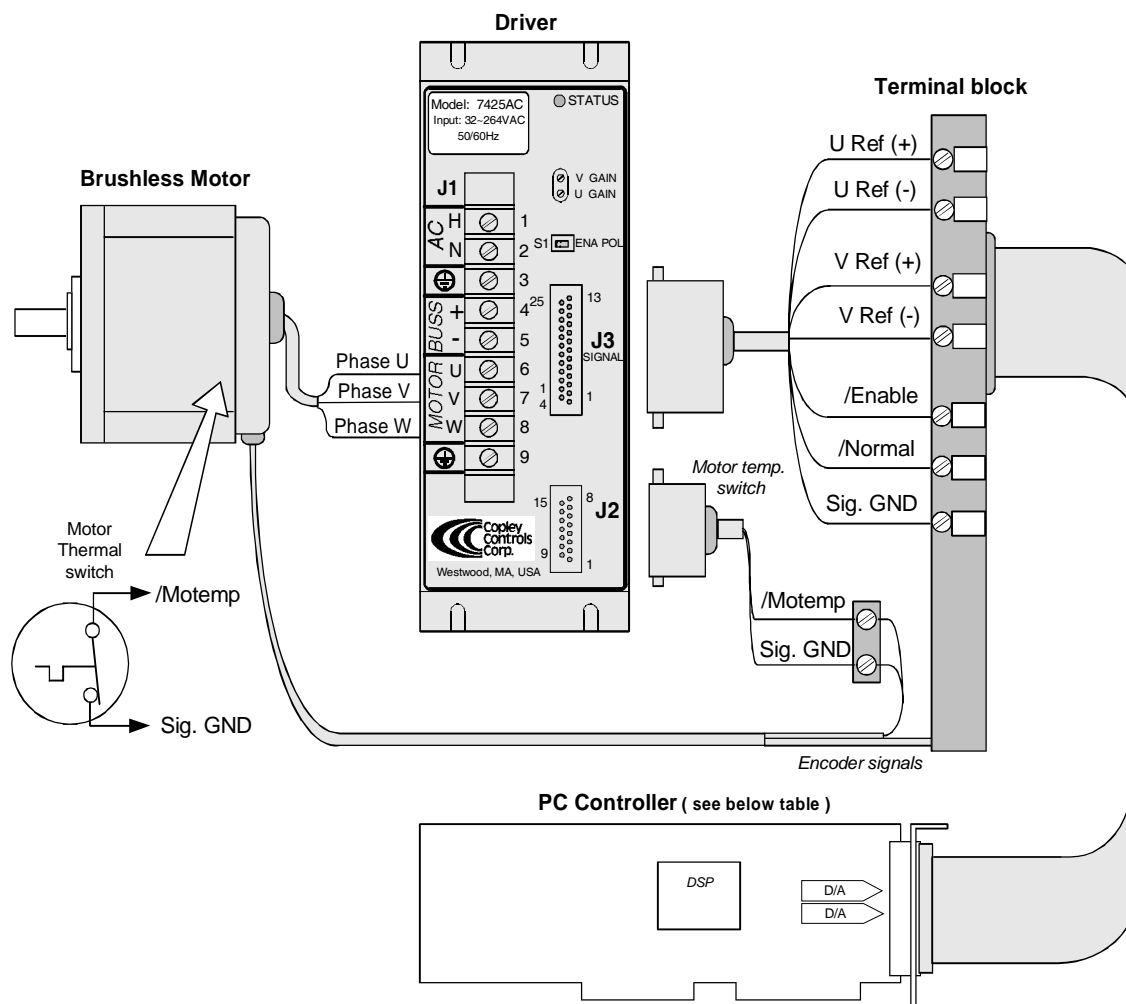

**CONTROLLERS**

Here is a list of several controllers available that perform sinusoidal commutation. These controllers use a DSP in conjunction with double DAC analog outputs to perform multi-axis motion control. They are configured for several buss platforms such as ISA, PC104, VME, and STD. For more information, about controllers, please contact the below manufacturers.

Manufacturer	Model	Description	Web site
ACS-Tech80	5651A	ISA bus card for to 4 Axis	<a href="http://www.acs-tech80.com">www.acs-tech80.com</a>
ACS-Tech80	SPiiPlus Series	Stand-alone controller	<a href="http://www.acs-tech80.com">www.acs-tech80.com</a>
PMD	DK 1231A-P	Developers Kit for 2 Axis	<a href="http://www.pmdcorp.com">www.pmdcorp.com</a>
Motion Engineering Inc.	PCX DSP	ISA bus card for to 4 Axis	<a href="http://www.motioneng.com">www.motioneng.com</a>
Delta Tau	PMAC1	ISA bus card for to 4 Axis	<a href="http://www.deltatau.com">www.deltatau.com</a>
Galil	DMC-1700	ISA bus card for to 4 Axis	<a href="http://www.galilmc.com">www.galilmc.com</a>

**MODELS 7225AC, 7425AC**  
**LINE-POWERED AC BRUSHLESS SERVO AMPLIFIERS**  
**WITH +/-10V ANALOG U-V INPUTS**

**OUTLINE DIMENSIONS**

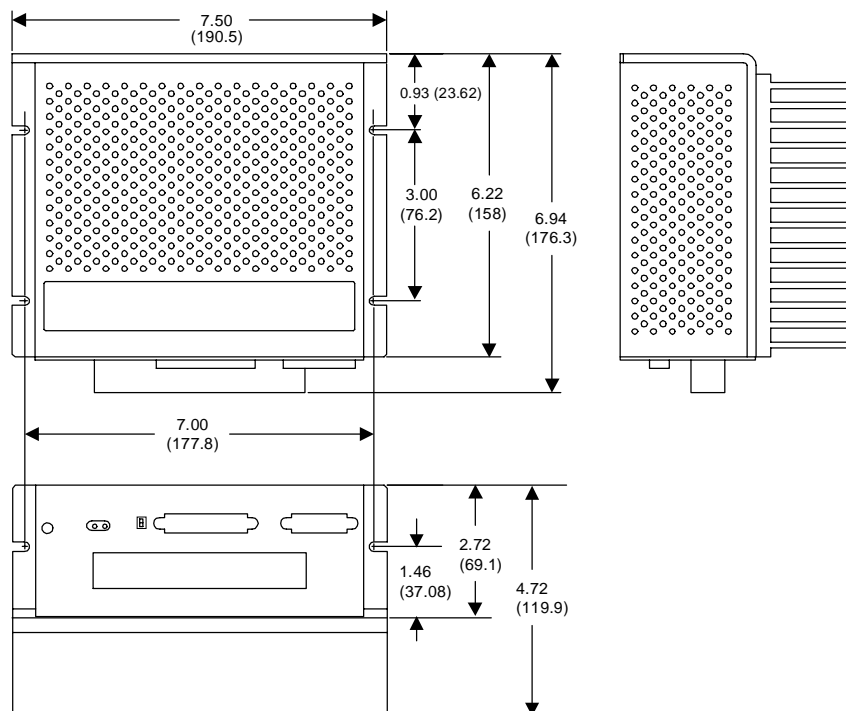

Dimensions in inches (mm)

**Weight** 3.71 lbs. (1.69 kg) without optional heatsink. Add 3.2 lbs. (1.47 kg) for heatsink.

**CONNECTORS** J1: Power & motor 9-position terminal strip  
 J2: Halls / Options 15-position female Sub-D type. #4-40 standoffs for cable shell lock screws  
 J3: Signal 25-position female Sub-D type. #4-40 standoffs for cable shell lock screws  
 Connector shells are connected to amplifier chassis for grounding/shielding

**ORDERING GUIDE**

Model 7225AC	20A peak, 10A continuous, from 32~132VAC, 50/60Hz AC mains
Model 7425AC	20A peak, 10A continuous, from 32~264VAC, 50/60Hz AC mains

Notes:  
1. Add "H" to model number to specify heatsink option.

**OTHER ANALOG BRUSHLESS MOTOR AMPLIFIERS**

*Low-drift, ±10V U-V Command Inputs, 24~180 Vdc power sources*

- 7225X1** 10 Acont, 25 Apeak,
- 7225X1-50** 15 Acont, 50 Apeak
- 7225X2** 2-axis, 10 Acont, 25 Apeak



Corporate Office, USA  
20 Dan Road  
Canton, MA 02021  
Tel: 781-828-8090  
Fax: 781-828-6547

Technical support: [sales@copleycontrols.com](mailto:sales@copleycontrols.com), or Internet Support: <http://www.copleycontrols.com>