

RELIABLE. RESPONSIVE. RELIABLE. RESPONSIVE. RELIABLE. RESPONSIVE. RELIABLE. RESPONSIVE. RELIABLE. RESPONSIVE. RELIABLE. RESPONSIVE. RELIABLE. RESPONSIVE. RELIABLE. RESPONSIVE. RELIABLE. RESPONSIVE. RELIABLE. RESPONSIVE. RELIABLE. RESPONSIVE.

What do you want to build today?®

STRUCTURAL ALUMINUM EXTRUSIONS CATALOG

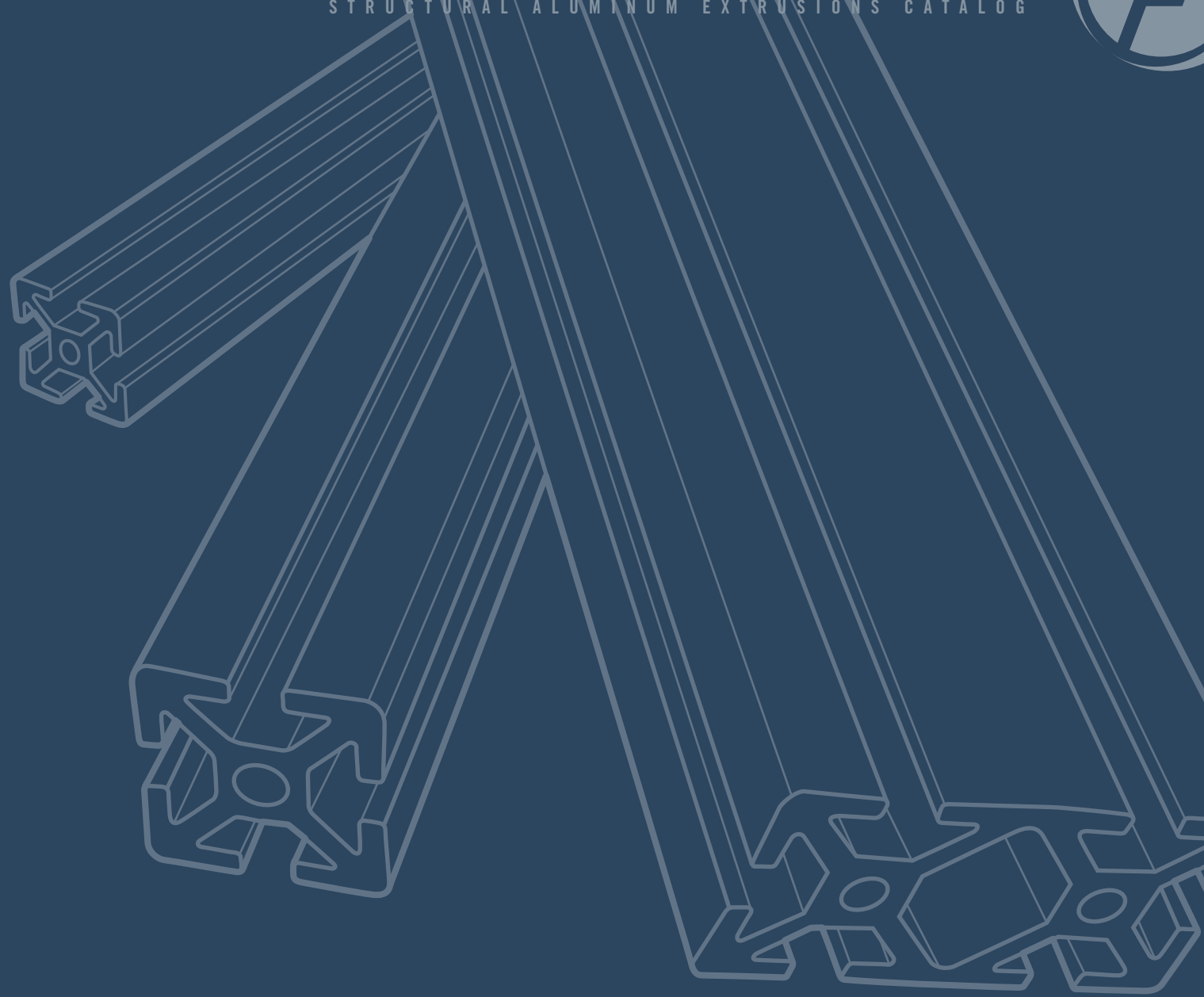

V.7 - 2009 ~ \$10.00
ISO 9001 REGISTERED



TSLOTS DesignPro™ Add-in for SolidWorks®

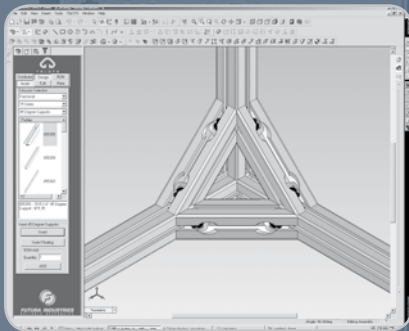
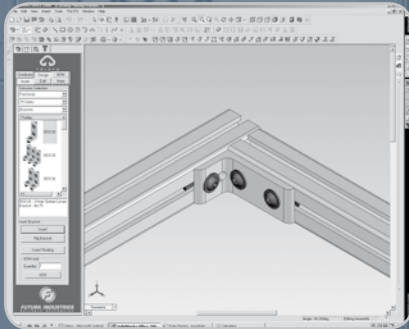
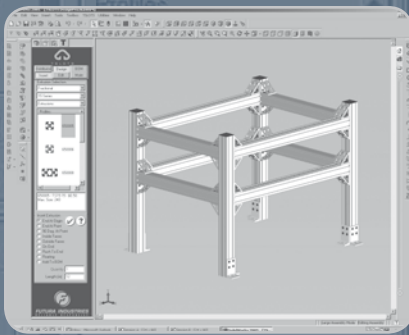

Save Time and Money with TSLOTS DesignPro™

The TSLOTS DesignPro™ is a design tool ADD - IN for SolidWorks® 2003, 2004, 2005 and 2006.

- Reduces Modular Framing Design Time by Over 50%
- Creates Automatic Bill of Material
- Provides Real-Time Pricing
- Provides Online Services
- RFQ / Ordering
- Project Status

TSLOTS Deflection Calculator/Beam Selector

Performs the following functions:

- Selects Beam by Allowable Stress
- Selects Beam by Allowable Deflection
- Calculates One Unknown Based on a Selected Beam
- 2D and 3D CAD Drawings

In addition to the SolidWorks® part and assembly files, the CD includes:

- 2D .dwg, .dxf
- 3D .step, .iges, .sat

TSLOTS Catalog and Price List

The TSLOTS Catalog and Price List are viewable in .pdf format.
A link to the Adobe website is available on the CD.

CALL OR GO ONLINE NOW TO REQUEST YOUR NEW CD-ROM

Phone: 800.824.2049 | www.tslots.com



Table of Contents

Introduction	iv		
How To Order	v		
TSLOTS Ideas	vi		
01 Technical Data	01:00		
TSLOTS Extrusion Advantages	01:02		
Extrusion Specifications	01:02		
Spring Lock Feature	01:02		
Fastener Torque Specifications	01:02		
T-Slot Radius	01:03		
Aluminum Alloy	01:03		
Anodizing	01:03		
Deflection Calculations	01:04		
TSLOTS DesignPro Introduction	01:05		
02 Structural Extrusions	02:00		
10 Series	02:02		
15 Series	02:08		
03 TSLOTS Brackets	03:00		
10 S Corner Brackets	03:02		
10 S Joining Plates	03:10		
15 S Corner Brackets	03:17		
15 S Joining Plates	03:25		
Transition Brackets	03:36		
04 Fasteners	04:00		
Fastener Application Test	04:02		
Economy T-nuts	04:03		
Standard T-nuts	04:04		
Drop In T-nuts	04:04		
Z-Nuts	04:06		
Economy Tslot Studs	04:06		
Butt Fasteners	04:06		
Anchor Fasteners	04:07		
End Fasteners	04:08		
Single Tab End Fastener	04:09		
Screws	04:10		
05 Dynamic & Structural Hinges	05:00		
Dynamic Hinges - 10 Series	05:02		
Dynamic Hinges - 15 Series	05:02		
Pivot Bracket - 90°	05:07		
Structural Hinges - 10 Series	05:08		
Structural Hinges - 15 Series	05:12		
Nylon Pivot Hinge - 15 Series	05:16		
06 TSLOTS Hardware	06:00		
Hinges	06:03		
Handles	06:06		
Door Catches	06:07		
Door Slide Track	06:11		
Panel Stiffener	06:11		
Panel Gasket	06:12		
Panel Mount Block	06:13		
Panel Mount Bracket	06:15		
Panel Retainer	06:15		
Mesh Panel Retainer	06:17		
Plastic Panels	06:19		
PVC Coated Wire Mesh	06:20		
Area Calculator Matrix	06:21		
Slatwall Panels	06:22		
45° Supports	06:23		
End Caps And Covers	06:24		
Table Tops	06:25		
Tool Hangers & Clamp	06:25		
Manifold Plates - 10 Series	06:27		
Manifold Plates - 15 Series	06:28		
Casters	06:30		
Caster Base Plate	06:35		
Glides, Mounts And Feet	06:38		
Base Plates - 10 Series	06:42		
Base Plates - 15 Series	06:43		
Base Plate - Floor Mount	06:44		
07 Stanchions	07:00		
Single Shaft Base	07:02		
Double Shaft Base	07:02		
Single Shaft Plates	07:03		
Cross Clamp	07:04		
Single Shaft Mounting Block	07:04		
Single Horizontal Base	07:05		
Double Horizontal Base	07:05		
Quick Clamp	07:06		
08 Linear Motion	08:00		
Bearings - 10 Series	08:02		
Bearings - 15 Series	08:05		
Economy Bearings - 10 Series	08:08		
Economy Bearings - 15 Series	08:11		
Brake Handle	08:14		
Roller Wheels	08:14		
Roller Wheel Bracket and Assemblies	08:15		
Machining Services	08:16		
Linear Bearing Replacement Pads	08:17		
09 Tools	09:00		
Allen Wrench Sets	09:02		
Cutters, Bits & Jigs	09:04		
Taps	09:04		
10 Extrusion Profiles	10:00		
Flat Stock	10:02		
Tubes	10:03		
Angles	10:04		
Gusset Profile & Nub	10:04		
Right Angle Nub Profile	10:05		

Panel Mount Profile	10:05
Single Flange Bearing Profiles	10:06
Double Bearing Bearing Profile	10:06
Retainer Angles	10:07
Door Side Tracks	10:07
11 Machining Services	11:00
Slot Locations	11:02
Ordering Notes	11:03
Order Example	11:04
Cut To Length	11:05
Tap	11:06
Access Hole	11:07
Door Handle Milling	11:08
Counterbore with Through Hole	11:08
Counterbore Anchor / Butt Fastening Assembly	11:09
Panels And Wire Mesh Cut	11:10
Slam Latch Machining	11:10
Miter Saw Cuts & Counterbore	11:11
Notch Services	11:12
Edge Radius for Panels	11:13
12 Metric	12:00
25 Series Extrusions	12:02
40 Series Extrusions	12:04
25 Series Corner Brackets	12:06
25 Series Joining Plates	12:15
40 Series Corner Brackets	12:21
40 Series Joining Plates	12:24
Economy T-Nuts	12:27
Standard T-Nuts	12:28
Drop In T-Nuts	12:29
Z-Nuts	12:30
Butt Fasteners	12:31
Anchor Fasteners	12:31
End Fasteners	12:32
Screws	12:34
Casters	12:35
Leveling Feet	12:36
Base Plates	12:38
End Caps / Covers	12:42
Other 25 S & 40 S Compatible Hardware	See Section 06
Machining Services	See Section 11
13 Index	13:00
Numeric	13:02

Appendix

INTRODUCTION

Thank you for ordering the NEW TSLOTS catalog. The TSLOTS catalog has been enhanced to include new profiles, accessories, TSLOTS brackets and many other parts designed to complete your project. TSLOTS is a product offering of Futura Industries, an aluminum extrusion company that provides stock and custom extrusions. If your project calls for a custom extrusion, we can provide it for you too!

The concept behind the T-Slotted aluminum extrusion is to make assembly of structures faster and easier than using welded steel. That's because the main component of the system is the TSLOTS design: insert a T-Nut and fastener into a T-Slot and tighten. It's that simple. No welding or grinding required. All you need to tighten your TSLOTS design is a few simple hand tools.

When you are done, you have a durable, strong, lightweight structure that's functional and attractive. The high-strength extruded aluminum profiles have a clear anodize surface that is scratch and corrosion resistant. Your structure never needs painting and is maintenance free.

PRODUCT WARRANTY

All Futura Industries (TSLOTS) products are guaranteed to be free of actual defect in material and workmanship for (1) full year from the date product was shipped from the factory. This warranty is limited to replacing or repairing, at Futura's option, F.O.B. Futura Industries, any part which, upon Futura inspection, is found to have a defect in material and/or workmanship. Futura in no event shall be liable for indirect or consequential damages arising out of the use of Futura products. Components purchased by Futura for inclusion by Futura shall be warranted only to the extent set out above and/or to the guarantee or warranty, if any, made by the supplier of said component.

No warranty is made by Futura, express or implied, that Futura products as used in a customer's design and specifications are fit for that customer's specific purpose. Apart from the above express warranty, there are no warranties, express, implied or statutory, including, without limitation, warranties of merchantability and fitness for a particular purpose, which extend beyond the description on the face hereof.

All product is shipped via best carrier, unless customer specified, F.O.B. Clearfield, Utah.

» *Returned unused product will be subject to a 20% restocking fee.*

HOW TO CONTACT US

Bldg H-11 Freeport Center
P.O. Box 160350
Clearfield, Utah 84016-0350

801.773.6282 Direct
800.824.2049 Toll Free
877.777.5753 Toll Free Fax

saleseng@tslots.com Email

MINIMUM ORDERS

We don't believe in minimums. If you need it, we'll ship to you. We appreciate all of your business, even the small stuff.

HOW TO ORDER

The fastest way for your order to be processed is to follow the format below.

ALWAYS INCLUDE:

- Ship to address (no P.O. Boxes)
- Shipping method
- Purchase order number

WHEN ORDERING, IT IS BEST TO LIST YOUR ORDER IN PRODUCT GROUPS

1. Extrusions (TSLOTS and Structural)
2. Custom Machining (As quoted by Futura Industries)
3. Panels (Plastic, Wire, Alupalite, etc.)
4. Machining Services (Cutting, Tapping, Access Holes, etc. for all aluminum and panels)
5. Hardware (Fasteners, Joining Plates, TSLOTS Brackets, Hinges, Hardware, Accessories, Linear Motion, Stanchions)
6. Special Instructions

	ITEM # (Descripton)	QTY	LENGTH	MACHING SERVICE NUMBER
Extrusions	650000 TS 1010	4	22"	660035 Side A and B
	650005 TS 1515	8	45.25"	660028 Side A and B
	650008 TS 1530	2	240"	
	650010 TS 1545	4	15"	660020 in Side A1, A2, A3 B1, B2, B3
Custom Machining	Cust #	4		Custom 45° Angle per drawing
Panels	655432	2	4 sq. ft.	1/4" Clear Polycarb 24" x 24" w/ 4 660097 see drawing
Machining	660002	4		CTL TS 1010
	660003	8		CTL TS 1515
	660007	4		CTL TS 1545
	660035	8		1/4 -20 Tap for TS 1010
	660028	16		15 S. Access Hole .295 thru
	660020	24		15 S Anchor Fastener C'bore
	660062	2		Cut Plastic Panel < 48"
	660097	4		Notch Panel for End Fastener Clear per drawing
Hardware	651161	80		15 S End Fastener w/ screw 5/16-18
	655000	8		TS 1010 End Cap
	655105	10		15 S Black T-Slot Cover
	651138	30		15 S Double End Fastener w/Screw 5/16-18
	Special Instructions:			

SUBMIT YOUR ORDER 3 WAYS

TOLL FREE
800.824.2049

TOLL FREE FAX
877.777.5753

EMAIL
saleseng@tslots.com

TSLOTS Ideas



clean rooms



work carts

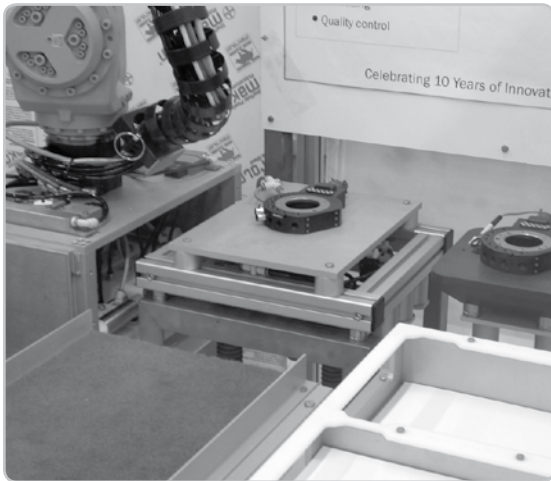

fixturing

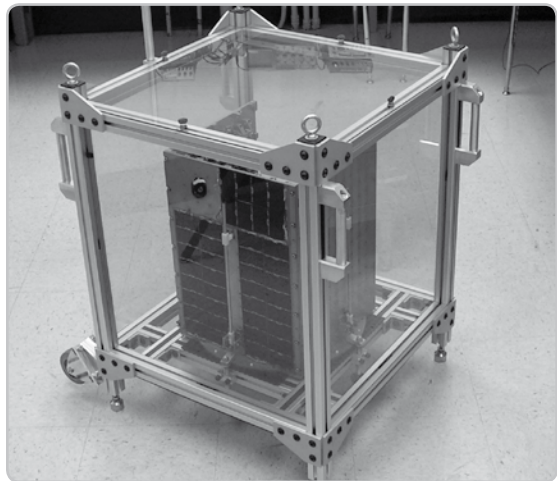

safety enclosure



inventory management



work table

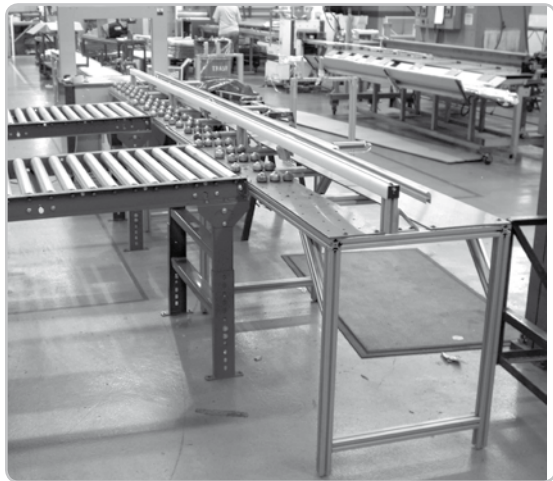

packaging



machine enclosures

TSLOTS Ideas

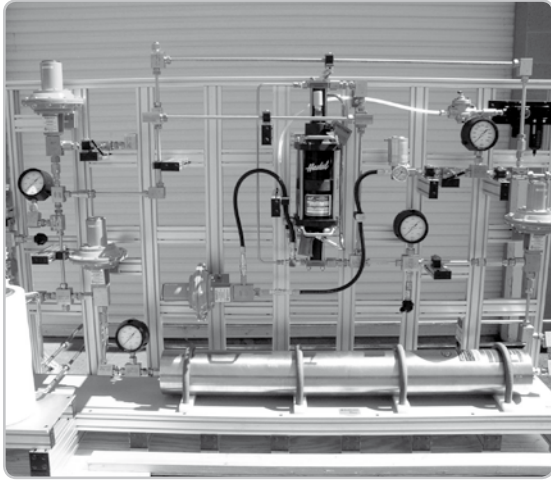

test hydraulics frames



test fixture

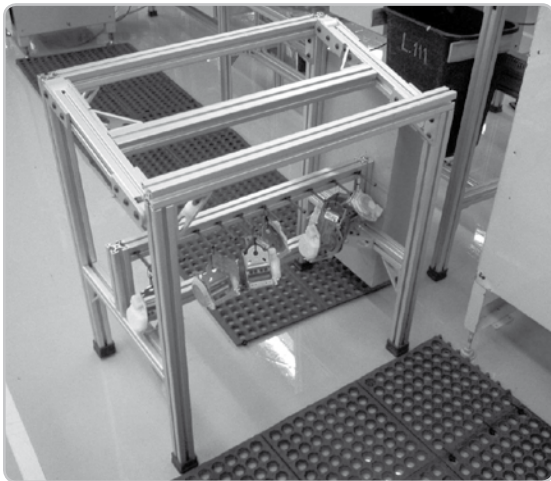

test rack



robotic enclosure



office shelving

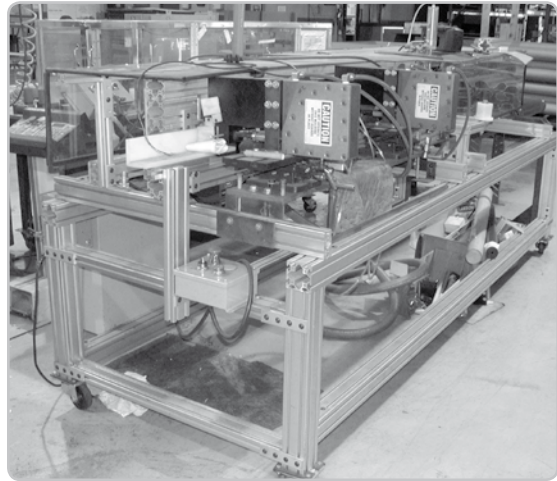

automation

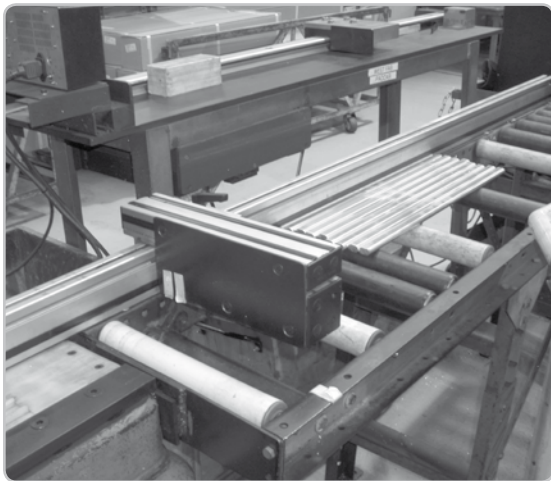

saw guide

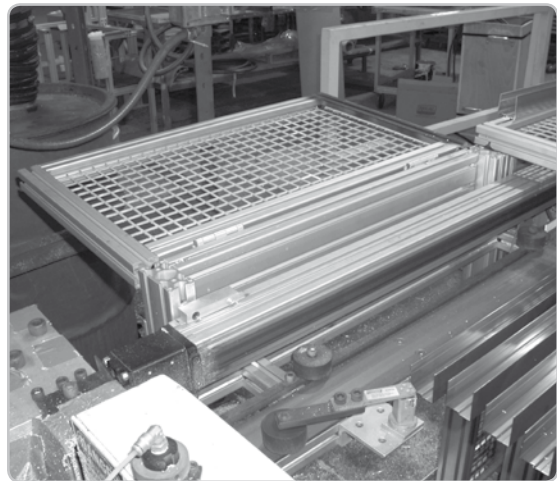

safety guarding

TSLOTS Ideas



ergonomic workstation



lean manufacturing



office furniture



point of purchase display

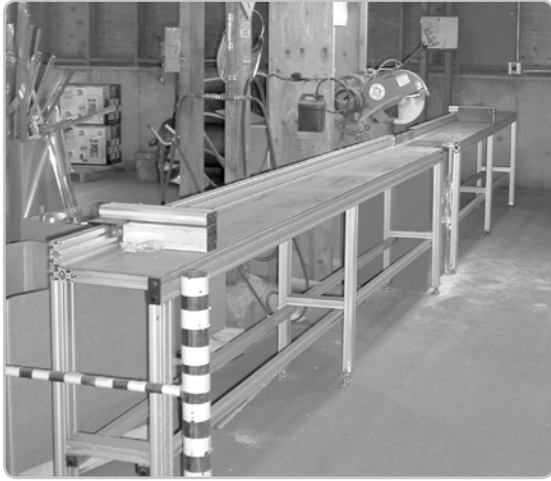

saw runout table

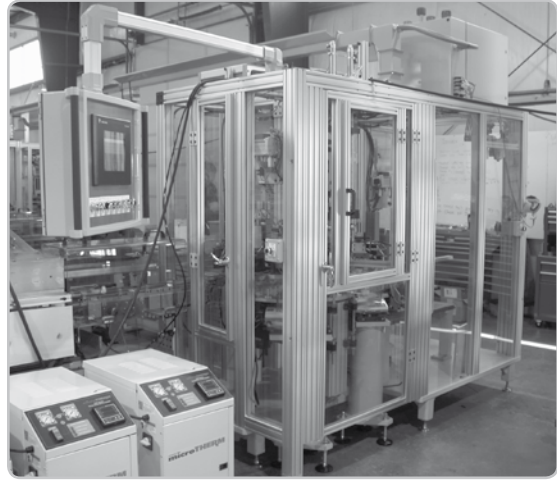

test enclosure

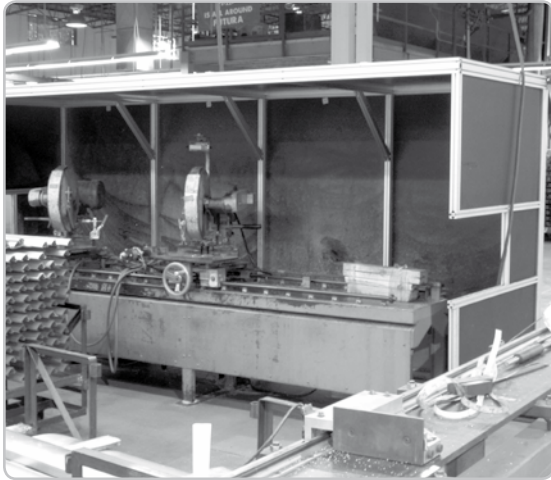

enclosure



training rooms