

## K Series Kit Motors

Frameless Kit Motors are the Reliable and Compact Approach to Build Your Own High-Performance Motor

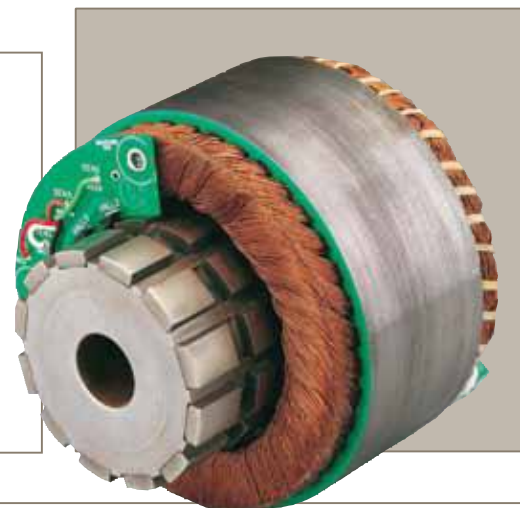

Direct drive motion construction gives equipment designers the advantages of lower costs, increased reliability and improved performance

Frameless kit motors are the ideal solution for machine designs that require high performance in small spaces. Kit Motors allow for direct integration with a mechanical transmission device, eliminating parts that add size and compliance. Use of frameless kit motors results in a smaller, more reliable motor package. Direct drive motion construction gives equipment designers the advantages of lower costs, increased reliability and improved performance.



### Features & Benefits:

- High torque from 0.5 in-lb (0.06 Nm) to 85.6 in-lb (9.7 Nm)
- High speeds up to 50,000 RPM
- Superior performance – high stiffness and better response
- High reliability – no mechanical transmission devices (couplings, flanges)
- Compact design – minimizes product size
- Low cogging - unique magnetic circuit design decreases cogging

### Applications:

- Automotive
- Machine tool
- Material handling
- Packaging
- Robotics
- Semiconductor

### When to Use:

- A significant cost savings
- Reduced mechanical complexity
- Greater design flexibility
- High performance in a compact package
- Improved dynamic response and settling
- Minimum motor size per application space
- Low cogging for smooth operation
- Low inertia for high acceleration

## Contact Information:

Parker Hannifin Corporation  
Electromechanical Automation Division  
5500 Business Park Drive  
Rohnert Park, CA 94928

phone: 800.358.9068 / 707.584.7558

fax: 707.584.8015

email: [emn\\_support@parker.com](mailto:emn_support@parker.com)

[www.parkermotion.com](http://www.parkermotion.com)



# K Series Kit Motors

## Advantages of Direct Drive Frameless Motors Compared to Traditional Coupled Motors

Our direct drive brushless kit motors consist of three components:

- **The stator and winding**
- **The rotor with high energy product neodymium magnets**
- **Hall sensor device for motor commutation**

The couplings, motor mounting brackets and extra bearings used in coupled-drive construction can create reliability and performance problems.

Direct drive motors provide higher dynamic stiffness by eliminating the compliance of shaft attachments.

Direct drive motor construction gives equipment designers the advantages of lowered costs, increased reliability and improved performance. Frameless Kit Motors are the most cost effective direct drive motor solutions available.

Kit motors save space in applications because the couplings, motor mounting brackets and extra bearings you would find in coupled drive construction are eliminated. Since there are fewer moving parts, the direct drive kit motor approach allows for a more reliable and compact design.

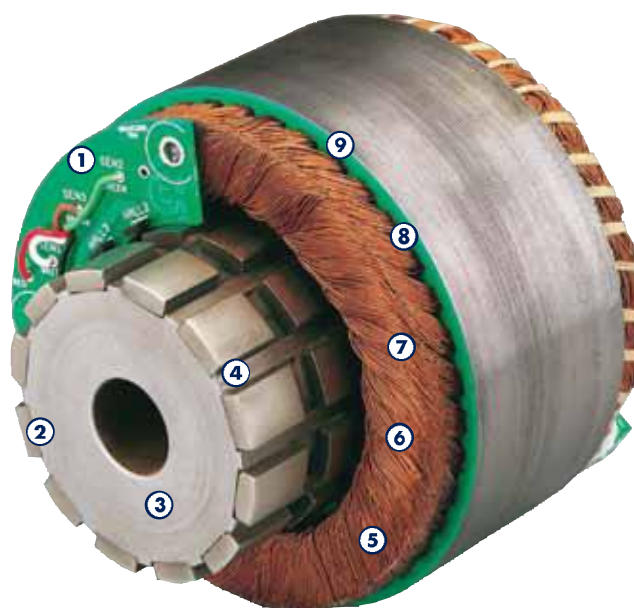

### Design Features

- ① **Pre-installed integral commutation board with Hall effects is prealigned for easy assembly. Motor and feedback as integrated unit.**
- ② **Rare earth magnets provide high-flux in a small volume, high resistance to thermal demagnetizing.**
- ③ **Rotor assembly for easy mounting directly on the drive shaft with or without keyway.**
- ④ **Machined grooves to securely lock magnets to rotor and ensures optimized radial location.**
- ⑤ **Class H insulation for high-temperature operation (up to 155°C) meeting UL approved requirements.**
- ⑥ **High-density copper winding for low thermal resistance and consistent performance across all motors.**
- ⑦ **Minimized end turns to maximize performance. Formed to minimize motor size.**
- ⑧ **Skewed laminations with odd slot counts reduce cogging for precise rotary motion with drastically reduced torque ripple even at low speeds.**
- ⑨ **Optimized slot fill for maximum torque-to-size ratio; hand inserted to obtain highest slot fill possible maximizing ampere-turns.**

## Frameless Motor Kit Selection

The selection of a particular frame size and winding for an application is dependent on:

- **Volume (diameter and length) requirement**
- **Power (torque and speed) requirement**
- **Voltage and current available or required**

The first two items are dependent on the load and performance specifications of the application. They result in the selection of a particular frame size (032 through 178) and stack length. The winding to be used will then be determined by voltage and current available or required.

**Voltage:** The bus voltage and maximum speed will approximately determine the required voltage constant ( $K_E$ ).

**Current:** The maximum load and acceleration will determine the amount of current required, determined by the torque constant ( $K_T$ ) associated with the selected voltage constant.

**Example:** Assume a requirement of 1,000 RPM at 50 oz-in. If a motor with a particular winding having  $K_E = 18.24$  V/1,000 RPM and  $K_T = 24.62$  oz in/amp is chosen, it will now require a voltage (BEMF) of 18 volts and current of 2 amp.

**NOTE:**  $K_E$  and  $K_T$  are directly proportional to each other. Increasing  $K_E$  will also increase  $K_T$ ; decreasing  $K_E$  will also decrease  $K_T$ . The result is that as the voltage requirement changes, the current requirement changes inversely.

Parker has a range of 3 windings that are available for each stack length within a particular frame size to meet the majority of your application requirements. Parker does have additional windings that are available upon request from Parker's Application Engineering Department.

Use the performance specifications and speed torque curves on the following pages to help determine the best solution for your specific application requirements.

Detailed information for all these windings can also be found on our web site at [www.parkermotion.com](http://www.parkermotion.com). Please contact Parker application engineers if you need assistance in selecting the proper motor size and power.

Frame Size	Stack Length Range		Continuous Stall Torque		Peak Torque		Rotor Inertia		Core Loss Pc	Winding-Amb Thermal Resist		Pole Count #	Motor Weight	
	mm	in	Nm	in-lb	Nm	in-lbs	Kg-m <sup>2</sup>	lb-in-sec <sup>2</sup>		°C/W	°C/W		kg	lb
K032	12.7	0.5	0.08	0.7	0.26	2.3	3.2 <sup>-7</sup>	2.8 <sup>-6</sup>	0.06	3.44	4	0.07	0.15	
	25.4	1	0.14	1.2	0.45	3.9	6.3 <sup>-7</sup>	5.6 <sup>-6</sup>	0.12	3.44	4	0.12	0.27	
	50.8	2	0.23	2.0	0.73	6.4	1.3 <sup>-6</sup>	1.1 <sup>-5</sup>	0.24	3.44	4	0.26	0.57	
K044	12.7	0.5	0.21	1.8	0.66	5.8	1.412 <sup>-6</sup>	1.25 <sup>-5</sup>	0.24	2.36	6	0.1	0.3	
	25.4	1	0.36	3.2	1.16	10.2	2.9 <sup>-6</sup>	2.6 <sup>-5</sup>	0.49	2.36	6	0.22	0.49	
	50.8	2	0.59	5.2	1.88	16.5	5.8 <sup>-6</sup>	5.1 <sup>-5</sup>	1.11	2.36	6	0.4	0.88	
K064	12.7	0.5	0.59	5.1	1.86	16.3	9.0 <sup>-6</sup>	8.0 <sup>-5</sup>	0.78	1.68	8	0.29	0.63	
	25.4	1	1.03	9.1	3.28	28.9	1.8 <sup>-5</sup>	1.6 <sup>-4</sup>	1.6	1.68	8	0.57	1.26	
	50.8	2	1.73	15.2	5.48	48.2	3.6 <sup>-5</sup>	3.2 <sup>-4</sup>	3.23	1.68	8	1.13	2.49	
K089	12.7	0.5	1.47	12.9	4.67	41.1	3.7 <sup>-5</sup>	3.3 <sup>-4</sup>	2.14	1.02	12	0.5	1.1	
	25.4	1	2.59	22.8	8.23	72.4	7.8 <sup>-6</sup>	6.9 <sup>-5</sup>	4.42	1.02	12	1	2.2	
	50.8	2	4.31	37.9	13.69	120.5	1.5 <sup>-4</sup>	1.3 <sup>-3</sup>	8.95	1.02	12	1.99	4.39	
K178	12.7	0.5	8.44	74.2	26.77	235.5	4.7 <sup>-4</sup>	4.1 <sup>-3</sup>	9.1	0.5	18	2.4	5.29	
	25.4	1	15.16	133.4	48.12	423.5	9.2 <sup>-4</sup>	8.1 <sup>-3</sup>	18.7	0.5	18	3.71	8.18	
	50.8	2	25.74	226.5	81.74	719.3	1.8 <sup>-3</sup>	1.6 <sup>-2</sup>	37.4	0.5	18	6.34	13.98	

Other stack lengths, windings and frame sizes are available. Contact Parker application engineering for more information.

# K Series Kit Motors

## Design Considerations

A number of methods are used to mount the stator and rotor assemblies to the customer product. The method chosen largely depends on the product design, performance requirements (torque, velocity, temperature, etc.) and the manufacturing capabilities of the user.

The following are some brief design consideration notes for your kit motor. Please contact our application engineering group if you require any assistance.

### Stator

The stator is typically mounted into a cylindrically shaped hole in the product. It is recommended that a banking step be incorporated at the bottom of the hole to assure accurate and repeatable location of the stator. Alternately, a non-ferrous "plug" can be used to provide a banking surface, which can be removed once the stator is fixed in place. The stator is typically held in position with adhesive for a permanent assembly or with set screws for a removable assembly.

### Housing

In designing the housing, provide a means for the stator lead wires (three) and the commutation Hall sensor PCB wires (five) to extend outside of the housing without interfering with the rotor/shaft assembly.

For volume production, a jig should be fabricated that will assure that the stator is located in the same position for each assembly. The yellow dot on the stator provides an index point for accomplishing this. This will eliminate the need to perform mechanical commutation alignment at final assembly.

### Rotor

Except for the smaller motors (K032 and K044), the ID of the rotor is usually larger than the shaft diameter. An adapter sleeve allows the rotor to be mounted to the shaft. The rotor/sleeve assembly must be positioned on the shaft such that the magnets are located in line with the stator assembly laminations.



Spring pin/retaining ring method (left); shoulder/adhesive method (right)

If the version in which the commutation PCB assembly is bonded to the end turns is being used, the commutation magnets must be located in proper proximity to the Hall sensors on the PCB. shows two methods for holding the rotor / sleeve on the shaft, either with adhesive or by using a spring pin and retaining ring. When using the adhesive method, a shoulder should be provided on the shaft to properly locate the rotor/sleeve assembly. When using the spring pin/retaining ring method, a slot must be provided in the sleeve that will engage the spring pin in the shaft, thus properly locating the rotor/sleeve assembly.

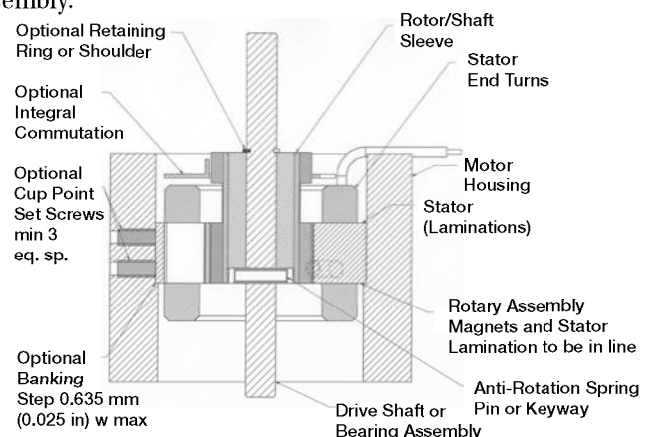

### Use our value added service to integrate your motor design



Half Housed Stator    Clamp-on Rotor

With our on-site design and manufacturing capabilities, Parker can offer value added solutions to assist with the integration of your frameless motor and provide "plug and play" solutions to your custom application requirements.

Please contact a Parker Application Engineer to discuss your needs.

Examples of our added design options are illustrated below. Value added capabilities include:

- **Aluminum end caps**
- **Clamp-on rotors**
- **Kevlar roving or stainless steel sleeve for ultimate reliability & speed**
- **Potting/encapsulation (including windings) to improve thermal performance and overall robustness**



## Speed-Torque Performance

Parker MotionSizer sizing software available for free download at: [www.parkermotion.com](http://www.parkermotion.com)

**NOTE:**  
 Please contact the factory for performance at voltages other than 340 VDC.

**Parker has numerous additional frame sizes, stack lengths, and windings available to meet virtually any practical combination of voltage and current requirement. Please contact us if you do not find a unit that meets your specific application performance, electrical and mechanical requirements.**

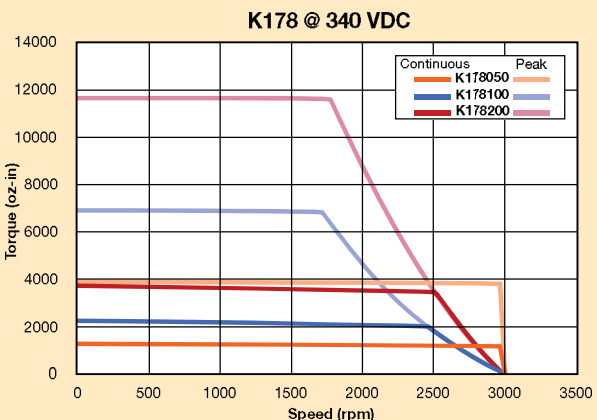
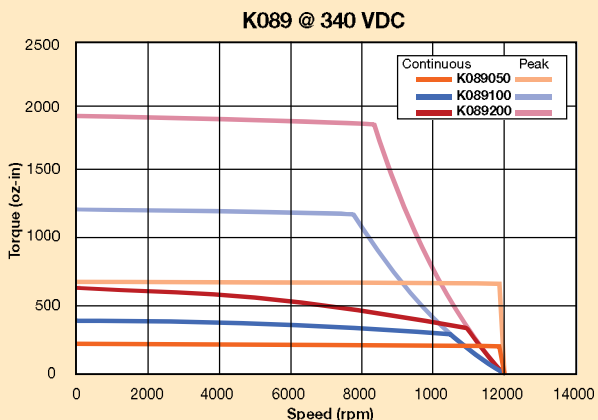
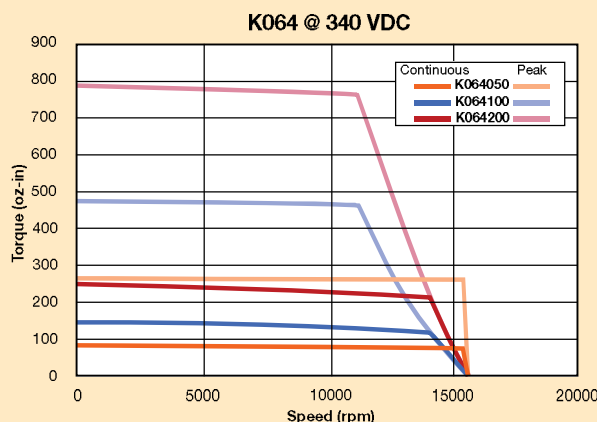
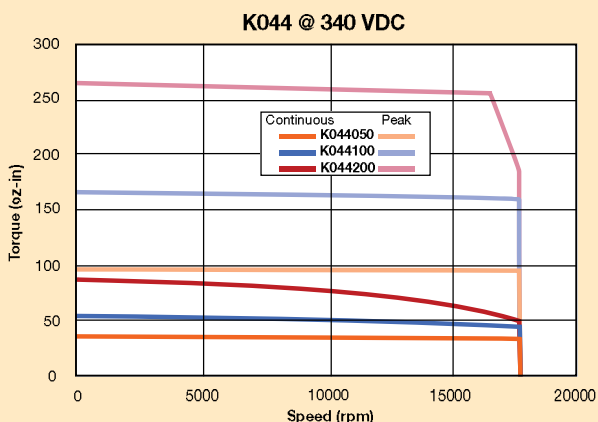
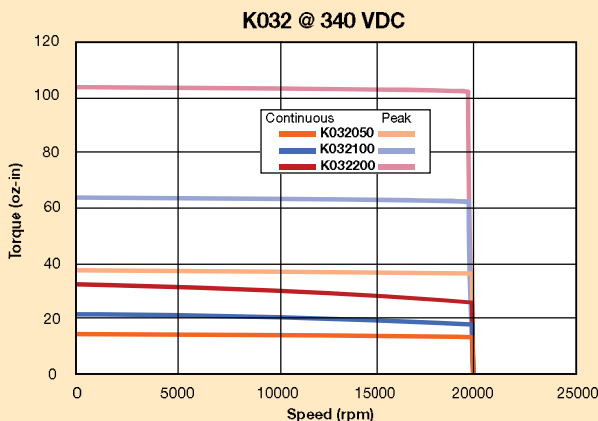

# K Series Kit Motors

## Frame Size 032 (32 mm O.D.) Model-Specific Performance\*

	Symbol	Units	K032050-	K032100-	K032200-						
<b>Stall Torque Continuous</b> <sup>(1,2,3)</sup>	Tcs	Nm	0.08	0.14	0.23						
		in-lb	0.73	1.25	2.04						
		oz-in	12	20	33						
<b>Peak Torque</b>	Tpk	Nm	0.26	0.45	0.73						
		in-lb	2.32	3.97	6.48						
		oz-in	37	64	104						
<b>Max Mechanical Speed**</b>			20000	20000	20000						
<b>Rated Torque</b> <sup>(1,2,3)</sup>	Tr	Nm	0.08	0.12	0.18						
		in-lb	0.68	1.10	1.58						
		oz-in	11	18	25						
<b>Rated Shaft Output Power</b> <sup>(1,2,3)</sup>	Pout	kW	0.160	0.259	0.372						
<b>DC Bus Voltage</b> <sup>(4)</sup>	Vmbus	VDC	340	340	340						
<b>AC Voltage</b> <sup>(4)</sup>	Vs	VAC	240	240	240						
<b>Winding-Amb Thermal Resist</b> <sup>(4)</sup>	Rthw-a	°C/W	3.44	3.44	3.44						
<b>Ambient Temp at Rating</b>	Tamb	°C	25	25	25						
<b>Max Winding Temp</b>	Tmax	°C	155	155	155						
<b>Motor Thermal Time Constant</b> <sup>(4)</sup>	tth	minutes	9.74	1.5	9.74						
<b>Rotor Shaft Viscous Damping</b> <sup>(4)</sup>	B	Nm/krpm	0.0001	0.0002	0.0004						
<b>Rotor Shaft Dynamic Friction</b> <sup>(4)</sup>	Tf	Nm	0.0003	0.0007	0.0013						
<b>Rotor Inertia</b> <sup>(4)</sup>	J	kg-m <sup>2</sup>	3.2 <sup>-7</sup>	6.3 <sup>-7</sup>	1.3 <sup>-6</sup>						
		in-lb-sec <sup>2</sup>	2.8 <sup>-6</sup>	5.6 <sup>-6</sup>	1.1 <sup>-6</sup>						
<b>Number of rotor magnet poles</b>	Np	# poles	4	4	4						
<b>Motor Weight</b> <sup>(4)</sup>		kg	0.07	0.12	0.26						
		lb	0.15	0.27	0.57						
<b>Motor UL Class</b>	F	UL class	H	H	H						
<b>Winding Constants</b>			<b>7Y</b>	<b>8Y</b>	<b>EY</b>	<b>7Y</b>	<b>8Y</b>	<b>EY</b>	<b>7Y</b>	<b>8Y</b>	<b>EY</b>
<b>Stall Current Continuous</b> <sup>(1,2,3)</sup>	lcs(rms)	Arms	3.55	2.78	1.75	3.06	2.40	1.51	2.49	1.95	1.23
	lcs(trap)	Amps DC	4.35	3.41	2.14	3.75	2.94	1.85	3.05	2.39	1.50
<b>Peak Current</b> <sup>(1,2,3)</sup>	lpk(rms)	Arms	11.23	8.79	5.53	9.69	7.58	4.77	7.87	6.16	3.88
	lpk(trap)	Amps DC	13.76	10.77	6.77	11.86	9.29	5.84	9.64	7.55	4.75
<b>Voltage Constant</b> <sup>(6,8)</sup>	Kb	V/rad/s	0.019	0.024	0.039	0.037	0.048	0.077	0.075	0.097	0.155
	Ke	Vrms/krpm	1.396	1.807	2.874	2.769	3.584	5.702	5.562	7.197	11.451
<b>Torque Constant</b> <sup>(6,8)</sup>	Kt(sine)	Nm/Arms	0.023	0.030	0.048	0.046	0.059	0.094	0.092	0.119	0.189
	Kt(trap)	oz-in/Amp DC	2.670	3.455	5.497	5.296	6.853	10.903	10.635	13.764	21.897
<b>Resistance</b> <sup>(6,8)</sup>	R	ohm	1.3	2.2	5.4	1.8	2.9	7.3	2.7	4.4	11.1
<b>Inductance</b> <sup>(7,8)</sup>	L	mH	0.7	1.1	2.8	1.3	2.2	5.6	2.6	4.4	11.2

\* K032 housed in a motor frame, typically an aluminum cylinder with 0.250 in thick walls, mounted to a 6 in x 6 in x 0.5 in aluminum plate. Parker MotionSizer sizing software available for free download at parkermotion.com.

\*\* Higher rpm possible with greater voltage and sleeved rotor

<sup>(1)</sup> Assumes motor is mounted to an aluminum plate with dimensions of 10" X 10" X 1/4" aluminum plate

<sup>(2)</sup> Maximum winding temperature is 155°C. Optional thermal protection device may be at a lower temperature. No thermal switch provided with kit motors as standard (typically integrated into motor housing); can be provided as custom.

<sup>(3)</sup> These ratings are valid for Parker Hannifin Drives. Other drives may not achieve the same ratings.

<sup>(4)</sup> Reference only

<sup>(5)</sup> ±10%

<sup>(7)</sup> ±30% @ 1kHz

<sup>(8)</sup> Measured Lead to Lead

## Frame Size 044 (44 mm O.D.) Model-Specific Performance\*

	Symbol	Units	K044050-	K044100-	K044200-						
<b>Stall Torque Continuous</b> <sup>(1,2,3)</sup>	$T_{CS}$	Nm	0.21	0.36	0.59						
		in-lb	1.8	3.22	5.24						
		oz-in	29.5	52	84						
<b>Peak Torque</b>	$T_{PK}$	Nm	0.66	1.16	1.88						
		in-lb	5.9	10.22	16.62						
		oz-in	93.7	164	266						
<b>Max Mechanical Speed**</b>			18000	18000	18000						
<b>Rated Torque</b> <sup>(1,2,3)</sup>	$T_r$	Nm	0.18	0.29	0.40						
		in-lb	1.6	2.55	3.52						
		oz-in	26.2	41	56						
<b>Rated Shaft Output Power</b> <sup>(1,2,3)</sup>	$P_{out}$	kW	0.3	0.539	0.648						
<b>DC Bus Voltage</b> <sup>(4)</sup>	$V_{mbus}$	VDC	340	340	340						
<b>AC Voltage</b> <sup>(4)</sup>	$V_s$	VAC	240	240	240						
<b>Winding-Amb Thermal Resist</b> <sup>(4)</sup>	$R_{thw-a}$	°C/W	2.36	2.36	2.36						
<b>Ambient Temp at Rating</b>	$T_{amb}$	°C	25	25	25						
<b>Max Winding Temp</b>	$T_{max}$	°C	155	155	155						
<b>Motor Thermal Time Constant</b> <sup>(4)</sup>	$t_{th}$	minutes	11.0	11	11						
<b>Rotor Shaft Viscous Damping</b> <sup>(4)</sup>	B	Nm/krpm	0.0004	0.0007	0.0014						
<b>Rotor Shaft Dynamic Friction</b> <sup>(4)</sup>	$T_f$	Nm	0.0010	0.0019	0.0039						
<b>Rotor Inertia</b> <sup>(4)</sup>	J	kg-m <sup>2</sup>	1.412 <sup>-6</sup>	2.9 <sup>-6</sup>	5.8 <sup>-6</sup>						
		in-lb-sec <sup>2</sup>	1.250 <sup>-5</sup>	2.6 <sup>-5</sup>	5.1 <sup>-5</sup>						
<b>Number of rotor magnet poles</b>	$N_p$	# poles	6	6	6						
<b>Motor Weight</b> <sup>(4)</sup>		kg	0.1	0.22	0.40						
		lb	0.3	0.49	0.88						
<b>Motor UL Class</b>	F	UL class	H	H	H						
<b>Winding Constants</b>			<b>7Y</b>	<b>8Y</b>	<b>EY</b>	<b>7Y</b>	<b>8Y</b>	<b>EY</b>	<b>7Y</b>	<b>8Y</b>	<b>EY</b>
<b>Stall Current Continuous</b> <sup>(1,2,3)</sup>	$I_{cs(rms)}$	Arms	4.63	3.7	2.31	4.01	3.19	1.60	3.28	2.61	1.64
	$I_{cs(trap)}$	Amps DC	5.67	4.5	2.83	4.91	3.91	1.95	4.01	3.20	2.00
<b>Peak Current</b> <sup>(1,2,3)</sup>	$I_{pk(rms)}$	Arms	14.63	11.7	7.31	12.67	10.09	5.04	10.35	8.24	5.17
	$I_{pk(trap)}$	Amps DC	17.92	14.3	8.95	15.52	12.36	6.17	12.68	10.10	6.33
<b>Voltage Constant</b> <sup>(6,8)</sup>	$K_b$	V/rad/s	0.037	0.0464	0.074	0.075	0.094	0.187	0.149	0.186	0.298
	$K_e$	Vrms/krpm	2.749	3.44	5.497	5.545	6.931	13.862	11.042	13.803	22.084
<b>Torque Constant</b> <sup>(6,8)</sup>	$K_t(sine)$	Nm/Arms	0.045	0.057	0.091	0.092	0.115	0.229	0.183	0.228	0.365
	$K_t(trap)$	oz-in/Amp DC	5.256	6.57	10.512	10.603	13.254	26.508	21.115	26.394	42.231
<b>Resistance</b> <sup>(6,8)</sup>	R	ohm	1.1	1.787	4.5	1.5	2.4	9.5	2.3	3.6	9.1
<b>Inductance</b> <sup>(7,8)</sup>	L	mH	0.8	1.3	3.2	1.6	2.5	10.0	3.2	5.0	12.8

\* K044 housed in a motor frame, typically an aluminum cylinder with 0.250 in thick walls, mounted to a 6 in x 6 in x 0.5 in aluminum plate. Parker MotionSizer sizing software available for free download at parkermotion.com.

\*\* Higher rpm possible with greater voltage and sleeved rotor

<sup>(1)</sup> Assumes motor is mounted to an aluminum plate with dimensions of 10" X 10" X 1/4" aluminum plate

<sup>(2)</sup> Maximum winding temperature is 155°C. Optional thermal protection device may be at a lower temperature. No thermal switch provided with kit motors as standard (typically integrated into motor housing); can be provided as custom.

<sup>(3)</sup> These ratings are valid for Parker Hannifin Drives. Other drives may not achieve the same ratings.

<sup>(4)</sup> Reference only

<sup>(6)</sup> ±10%

<sup>(7)</sup> ±30% @ 1kHz

<sup>(8)</sup> Measured Lead to Lead

# K Series Kit Motors

## Frame Size 064 (64 mm O.D.) Model-Specific Performance\*

	Symbol	Units	K064050-	K064100-	K064200-						
Stall Torque Continuous <sup>(1,2,3)</sup>	T <sub>CS</sub>	Nm	0.59	1.03	1.73						
		in-lb	5.18	9.16	15.28						
		oz-in	83	147	244						
Peak Torque	T <sub>PK</sub>	Nm	1.86	3.28	5.48						
		in-lb	16.42	29.05	48.51						
		oz-in	263	465	776						
Max Mechanical Speed**			15500	15500	15500						
Rated Torque <sup>(1,2,3)</sup>	T <sub>r</sub>	Nm	0.49	0.86	1.56						
		in-lb	4.30	7.58	13.77						
		oz-in	69	121	220						
Rated Shaft Output Power <sup>(1,2,3)</sup>	P <sub>out</sub>	kW	0.783	0.964	0.866						
DC Bus Voltage <sup>(4)</sup>	V <sub>mbus</sub>	VDC	340	340	340						
AC Voltage <sup>(4)</sup>	V <sub>s</sub>	VAC	240	240	240						
Winding-Amb Thermal Resist <sup>(4)</sup>	R <sub>thw-a</sub>	°C/W	1.68	1.68	1.68						
Ambient Temp at Rating	T <sub>amb</sub>	°C	25	25	25						
Max Winding Temp	T <sub>max</sub>	°C	155	155	155						
Motor Thermal Time Constant <sup>(4)</sup>	t <sub>th</sub>	minutes	22	22	22						
Rotor Shaft Viscous Damping <sup>(4)</sup>	B	Nm/krpm	0.0010	0.0021	0.0042						
Rotor Shaft Dynamic Friction <sup>(4)</sup>	T <sub>f</sub>	Nm	0.0030	0.0060	0.0120						
Rotor Inertia <sup>(4)</sup>	J	kg-m <sup>2</sup>	9.0 <sup>-6</sup>	1.8 <sup>-5</sup>	3.6 <sup>-5</sup>						
		in-lb-sec <sup>2</sup>	8.0 <sup>-5</sup>	1.6 <sup>-4</sup>	3.2 <sup>-4</sup>						
Number of rotor magnet poles	N <sub>p</sub>	# poles	8	8	8						
Motor Weight <sup>(4)</sup>		kg	0.29	0.57	1.13						
		lb	0.63	1.26	2.49						
Motor UL Class	F	UL class	H	H	H						
<b>Winding Constants</b>			<b>8Y</b>	<b>9Y</b>	<b>EY</b>	<b>8Y</b>	<b>9Y</b>	<b>EY</b>	<b>8Y</b>	<b>9Y</b>	<b>EY</b>
Stall Current Continuous <sup>(1,2,3)</sup>	I <sub>cs(rms)</sub>	Arms	4.44	3.53	2.78	3.92	3.13	2.46	3.28	2.61	2.05
	I <sub>cs(trap)</sub>	Amps DC	5.43	4.33	3.41	4.81	3.83	3.01	4.01	3.20	2.52
Peak Current <sup>(1,2,3)</sup>	I <sub>pk(rms)</sub>	Arms	14.02	11.16	8.79	12.40	9.88	7.77	10.36	8.25	6.49
	I <sub>pk(trap)</sub>	Amps DC	17.17	13.67	10.76	15.19	12.10	9.52	12.68	10.10	7.95
Voltage Constant <sup>(6,8)</sup>	K <sub>b</sub>	V/rad/s	0.109	0.136	0.174	0.218	0.272	0.348	0.435	0.544	0.696
	K <sub>e</sub>	Vrms/krpm	8.053	10.066	12.884	16.105	20.132	25.769	32.211	40.264	51.537
Torque Constant <sup>(6,8)</sup>	K <sub>t(sine)</sub>	Nm/Arms	0.133	0.166	0.213	0.266	0.333	0.426	0.533	0.666	0.852
	K <sub>t(trap)</sub>	oz-in/Amp DC	15.399	19.249	24.638	30.798	38.498	49.277	61.596	76.995	98.554
Resistance <sup>(6,8)</sup>	R	ohm	1.7	2.7	4.4	2.2	3.5	5.6	3.2	5.0	8.1
Inductance <sup>(7,8)</sup>	L	mH	2.0	3.1	5.1	4.0	6.3	10.2	8.0	12.5	20.4

\* K064 housed in a motor frame, typically an aluminum cylinder with 0.250 in thick walls, mounted to a 6 in x 6 in x 0.5 in aluminum plate. Parker MotionSizer sizing software available for free download at [parkermotion.com](http://parkermotion.com).

\*\* Higher rpm possible with greater voltage and sleeved rotor

<sup>(1)</sup> Assumes motor is mounted to an aluminum plate with dimensions of 10" X 10" X 1/4" aluminum plate

<sup>(2)</sup> Maximum winding temperature is 155°C. Optional thermal protection device may be at a lower temperature. No thermal switch provided with kit motors as standard (typically integrated into motor housing); can be provided as custom.

<sup>(3)</sup> These ratings are valid for Parker Hannifin Drives. Other drives may not achieve the same ratings.

<sup>(4)</sup> Reference only

<sup>(5)</sup> ±10%

<sup>(7)</sup> ±30% @ 1kHz

<sup>(8)</sup> Measured Lead to Lead



## Frame Size 089 (89 mm O.D.) Model-Specific Performance\*

	Symbol	Units	K089050-	K089100-	K089200-						
<b>Stall Torque Continuous</b> <sup>(1,2,3)</sup>	$T_{CS}$	Nm	1.47	2.59	4.31						
		in-lb	13.01	22.94	38.12						
		oz-in	208	367	610						
<b>Peak Torque</b>	$T_{PK}$	Nm	4.67	8.23	13.69						
		in-lb	41.30	72.84	121.19						
		oz-in	661	1166	1939						
<b>Max Mechanical Speed**</b>			12000	12000	12000						
<b>Rated Torque</b> <sup>(1,2,3)</sup>	$T_r$	Nm	1.16	2.07	3.77						
		in-lb	10.23	18.35	33.32						
		oz-in	164	294	533						
<b>Rated Shaft Output Power</b> <sup>(1,2,3)</sup>	$P_{out}$	kW	1.443	1.716	1.590						
<b>DC Bus Voltage</b> <sup>(4)</sup>	$V_{mbus}$	VDC	340	340	340						
<b>AC Voltage</b> <sup>(4)</sup>	$V_s$	VAC	240	240	240						
<b>Winding-Amb Thermal Resist</b> <sup>(4)</sup>	$R_{thw-a}$	°C/W	1.02	1.02	1.02						
<b>Ambient Temp at Rating</b>	$T_{amb}$	°C	25	25	25						
<b>Max Winding Temp</b>	$T_{max}$	°C	155	155	155						
<b>Motor Thermal Time Constant</b> <sup>(4)</sup>	$t_{th}$	minutes	28	28	28						
<b>Rotor Shaft Viscous Damping</b> <sup>(4)</sup>	B	Nm/krpm	0.0034	0.0068	0.0136						
<b>Rotor Shaft Dynamic Friction</b> <sup>(4)</sup>	$T_f$	Nm	0.0097	0.0193	0.0387						
<b>Rotor Inertia</b> <sup>(4)</sup>	J	kg-m <sup>2</sup>	3.7 <sup>-5</sup>	7.8 <sup>-6</sup>	1.5 <sup>-4</sup>						
		in-lb-sec <sup>2</sup>	3.3 <sup>-4</sup>	6.9 <sup>-5</sup>	1.3 <sup>-3</sup>						
<b>Number of rotor magnet poles</b>	$N_p$	# poles	12	12	12						
<b>Motor Weight</b> <sup>(4)</sup>		kg	0.50	1.00	1.99						
		lb	1.1	2.2	4.39						
<b>Motor UL Class</b>	F	UL class	H	H	H						
<b>Winding Constants</b>			<b>6Y</b>	<b>7Y</b>	<b>9Y</b>	<b>6Y</b>	<b>7Y</b>	<b>9Y</b>	<b>4Y</b>	<b>7Y</b>	<b>9Y</b>
<b>Stall Current Continuous</b> <sup>(1,2,3)</sup>	$I_{cs(rms)}$	Arms	8.44	6.77	4.30	7.44	5.97	3.79	9.96	4.97	3.15
	$I_{cs(trap)}$	Amps DC	10.33	8.30	5.26	9.12	7.32	4.64	12.19	6.09	3.86
<b>Peak Current</b> <sup>(1,2,3)</sup>	$I_{pk(rms)}$	Arms	26.66	21.40	13.58	23.52	18.88	11.98	31.46	15.71	9.97
	$I_{pk(trap)}$	Amps DC	32.66	26.21	16.63	28.81	23.12	14.67	38.53	19.24	12.21
<b>Voltage Constant</b> <sup>(6,8)</sup>	$K_b$	V/rad/s	0.145	0.178	0.279	0.290	0.357	0.558	0.357	0.714	1.115
	$K_e$	Vrms/krpm	10.733	13.210	20.641	21.467	26.420	41.282	26.420	52.841	82.564
<b>Torque Constant</b> <sup>(6,8)</sup>	$K_{t(sine)}$	Nm/Arms	0.178	0.218	0.341	0.355	0.437	0.683	0.437	0.874	1.366
	$K_{t(trap)}$	oz-in/Amp DC	20.525	25.261	39.471	41.050	50.523	78.942	50.523	101.046	157.884
<b>Resistance</b> <sup>(6,8)</sup>	R	ohm	0.8	1.2	3.0	1.0	1.6	3.9	0.6	2.3	5.7
<b>Inductance</b> <sup>(7,8)</sup>	L	mH	1.2	1.8	4.5	2.4	3.7	8.9	1.8	7.3	17.9

\* K089 housed in a motor frame, typically an aluminum cylinder with 0.250 in thick walls, mounted to a 8 in x 8 in x 0.5 in aluminum plate. Parker MotionSizer sizing software available for free download at parkermotion.com.

\*\* Higher rpm possible with greater voltage and sleeved rotor

<sup>(1)</sup> Assumes motor is mounted to an aluminum plate with dimensions of 12" X 12" X 1/2" aluminum plate

<sup>(2)</sup> Maximum winding temperature is 155°C. Optional thermal protection device may be at a lower temperature. No thermal switch provided with kit motors as standard (typically integrated into motor housing); can be provided as custom.

<sup>(3)</sup> These ratings are valid for Parker Hannifin Drives. Other drives may not achieve the same ratings.

<sup>(4)</sup> Reference only

<sup>(6)</sup> ±10%

<sup>(7)</sup> ±30% @ 1kHz

<sup>(8)</sup> Measured Lead to Lead

# K Series Kit Motors

## Frame Size 178 (178 mm O.D.) Model-Specific Performance\*

	Symbol	Units	K178050-	K178100-	K178200-						
Stall Torque Continuous <sup>(1,2,3)</sup>	T <sub>CS</sub>	Nm	8.44	15.16	25.74						
		in-lb	74.67	134.18	227.75						
		oz-in	1195	2147	3644						
Peak Torque	T <sub>PK</sub>	Nm	26.77	48.12	81.74						
		in-lb	236.87	425.88	723.41						
		oz-in	3790	6814	11575						
Max Mechanical Speed**			6000	6000	6000						
Rated Torque <sup>(1,2,3)</sup>	T <sub>r</sub>	Nm	7.44	13.94	24.35						
		in-lb	65.83	123.37	215.50						
		oz-in	1053	1974	3448						
Rated Shaft Output Power <sup>(1,2,3)</sup>	P <sub>out</sub>	kW	2.321	2.372	2.099						
DC Bus Voltage <sup>(4)</sup>	V <sub>mbus</sub>	VDC	340	340	340						
AC Voltage <sup>(4)</sup>	V <sub>s</sub>	VAC	240	240	240						
Winding-Amb Thermal Resist <sup>(4)</sup>	R <sub>thw-a</sub>	°C/W	0.5	0.5	0.5						
Ambient Temp at Rating	T <sub>amb</sub>	°C	25	25	25						
Max Winding Temp	T <sub>max</sub>	°C	155	155	155						
Motor Thermal Time Constant <sup>(4)</sup>	t <sub>th</sub>	minutes	108	108	108						
Rotor Shaft Viscous Damping <sup>(4)</sup>	B	Nm/krpm	0.0561	0.1123	0.2246						
Rotor Shaft Dynamic Friction <sup>(4)</sup>	T <sub>f</sub>	Nm	0.0485	0.0970	0.1940						
Rotor Inertia <sup>(4)</sup>	J	kg-m <sup>2</sup>	4.7 <sup>-4</sup>	9.2 <sup>-4</sup>	1.8 <sup>-3</sup>						
		in-lb-sec <sup>2</sup>	4.1 <sup>-3</sup>	8.1 <sup>-3</sup>	1.6 <sup>-2</sup>						
Number of rotor magnet poles	N <sub>p</sub>	# poles	18	18	18						
Motor Weight <sup>(4)</sup>		kg	2.40	3.71	6.34						
		lb	5.29	8.18	13.98						
Motor UL Class	F	UL class	H	H	H						
<b>Winding Constants</b>			6Y	8Y	EY	8Y	9Y	EY	8Y	9Y	EY
Stall Current Continuous <sup>(1,2,3)</sup>	I <sub>cs(rms)</sub>	Arms	16.94	10.68	6.74	9.60	7.60	6.06	8.15	6.46	5.15
	I <sub>cs(trap)</sub>	Amps DC	20.75	13.08	8.26	11.75	9.31	7.42	9.98	7.91	6.30
Peak Current <sup>(1,2,3)</sup>	I <sub>pk(rms)</sub>	Arms	53.54	33.75	21.30	30.32	24.03	19.14	25.76	20.41	16.26
	I <sub>pk(trap)</sub>	Amps DC	65.58	41.33	26.09	37.14	29.43	23.44	31.55	25.00	19.91
Voltage Constant <sup>(6,8)</sup>	K <sub>b</sub>	V/rad/s	0.410	0.649	1.024	1.297	1.639	2.048	2.595	3.277	4.097
	K <sub>e</sub>	Vrms/krpm	30.340	48.039	75.851	96.059	121.337	151.672	192.118	242.675	303.344
Torque Constant <sup>(6,8)</sup>	K <sub>t(sine)</sub>	Nm/Arms	0.502	0.795	1.255	1.589	2.007	2.509	3.178	4.014	5.017
	K <sub>t(trap)</sub>	oz-in/Amp DC	58.019	91.863	145.047	183.691	232.030	290.038	367.381	464.060	580.076
Resistance <sup>(6,8)</sup>	R	ohm	0.4	1.0	2.5	1.2	2.0	3.1	1.7	2.7	4.3
Inductance <sup>(7,8)</sup>	L	mH	1.5	3.8	9.6	7.7	12.2	19.1	15.3	24.5	38.2

\* K178 housed in a motor frame, typically an aluminum cylinder with 0.250 in thick walls, mounted to a 8 in x 8 in x 0.5 in aluminum plate. Parker MotionSizer sizing software available for free download at parkermotion.com.

\*\* Higher rpm possible with greater voltage and sleeved rotor

<sup>(1)</sup> Assumes motor is mounted to an aluminum plate with dimensions of 12" X 12" X 1" aluminum plate

<sup>(2)</sup> Maximum winding temperature is 155°C. Optional thermal protection device may be at a lower temperature. No thermal switch provided with kit motors as standard (typically integrated into motor housing); can be provided as custom.

<sup>(3)</sup> These ratings are valid for Parker Hannifin Drives. Other drives may not achieve the same ratings.

<sup>(4)</sup> Reference only

<sup>(6)</sup> ±10%

<sup>(7)</sup> ±30% @ 1kHz

<sup>(8)</sup> Measured Lead to Lead

## Dimensions

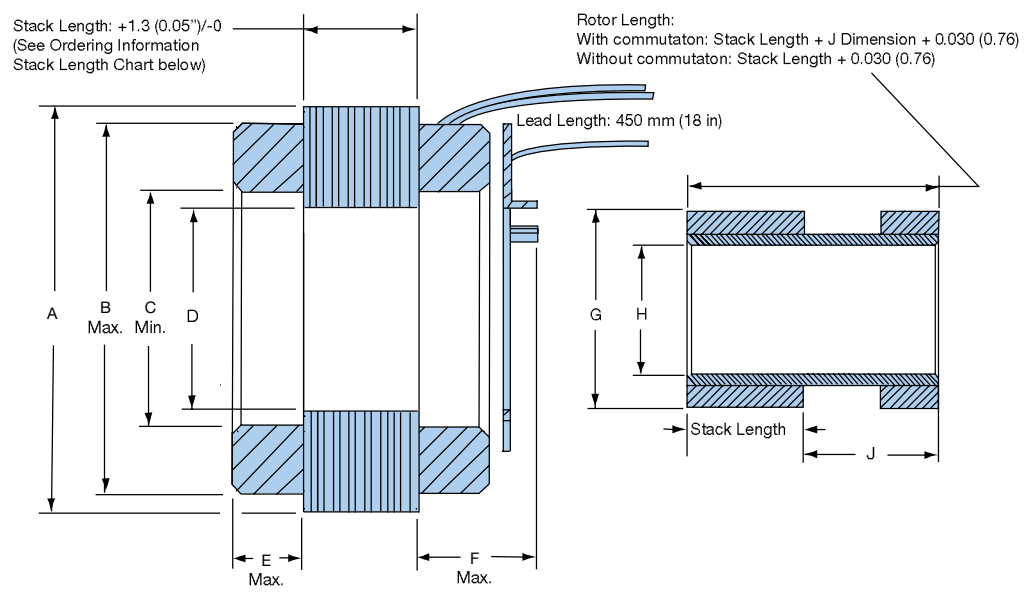

Frame Size	Dimensions – in (mm)									
	A O.D.	B End Turns O.D. Max	C End Turns I.D. Min	D I.D.	E End Turns Length Max	F Commutation Length	G Rotor O.D. Max	H Rotor I.D.	J Commutation Magnet Length	
<b>K032</b>	1.251 (31.78)	1.17	0.65	0.593 (15.06)	0.25	0.57 (14.5)	0.559	0.301 (7.65)	0.52 (13.2)	
	1.249 (31.72)	(29.7)	(16.5)	0.583 (14.80)	(6.4)		(14.20)	0.299 (7.60)		
<b>K044</b>	1.751 (44.48)	1.65	1.02	0.880 (22.35)	0.31	0.65 (16.5)	0.845	0.551 (14.00)	0.58 (14.7)	
	1.748 (44.40)	(42.0)	(25.9)	0.870 (22.10)	(7.9)		(21.46)	0.549 (13.95)		
<b>K064</b>	2.501 (63.53)	2.39	1.50	1.385 (35.18)	0.38	0.69 (17.5)	1.350	0.927 (23.55)	0.62 (15.7)	
	2.498 (63.45)	(60.7)	(38.1)	1.375 (34.92)	(9.7)		(34.29)	0.925 (23.50)		
<b>K089</b>	3.501 (88.93)	3.38	2.15	2.105 (53.47)	0.39	0.69 (17.5)	2.050	1.601 (40.67)	0.66 (16.7)	
	3.498 (88.85)	(85.9)	(54.6)	2.095 (53.21)	(9.9)		(52.07)	1.599 (40.61)		
<b>K178</b>	7.003 (177.88)	6.80	4.39	4.356 (110.65)	0.60	*	4.319	3.771 (95.78)	*	
	6.997 (177.72)	(172.7)	(111.5)	4.346 (110.39)	(15.3)		(109.70)	3.769 (95.73)		

\*Integral commutation not available

## Signal Timing

### Motor Signal

Power Leads	Forward
SEN X	Red
SEN Y	Black
SEN Z	White

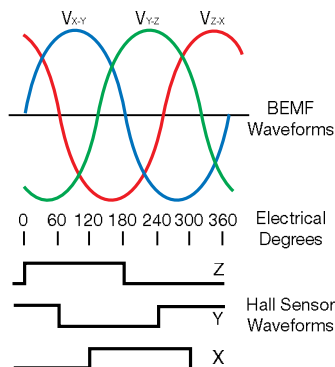

### Commutation Assembly

Sensor Leads	Forward	Rearward
SEN Z	Brown	Brown
SEN Y	Green	White
SEN X	White	Green
+5 V	Violet	Violet
Ground	Gray	Gray

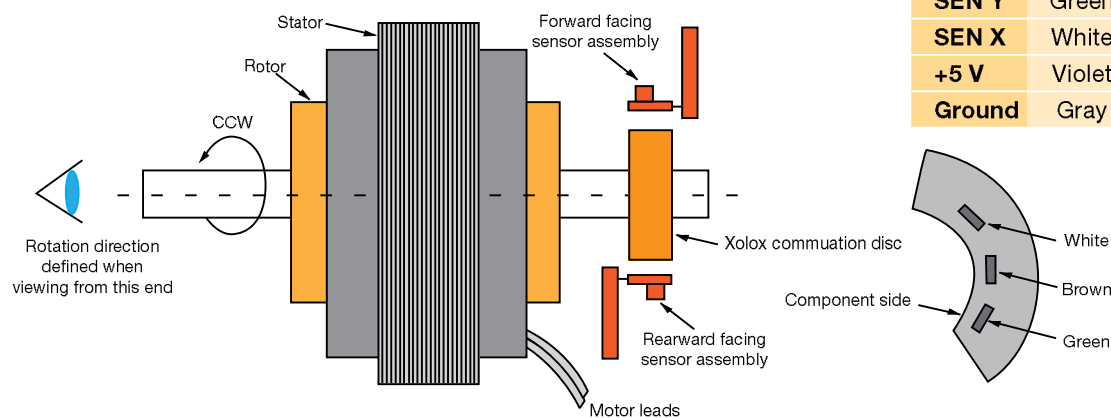

## Ordering Information

### Order Example:

① K ② 044 ③ 100 ④ E ⑤ Y ⑥ 2

Fill in an order code from each of the numbered fields to create a complete model order code.

#### ① Series

K Frameless Kit Motor

#### ② Frame Size (Stator O.D.)

032 32 mm  
 044 44 mm  
 064 64 mm  
 089 89 mm  
 178 178 mm

#### ③ Stack Length

050 0.50 in  
 100 1.00 in  
 200 2.00 in

#### ④ Windings

Refer to "Winding Constants" for selected frame size for winding performance and selection (pages 5-9)

#### ⑤ Connection Options\*

Y Wye

\*Consult factory for special connection options

#### ⑥ Commutation\*

1 Without  
 2 With integral

\*Integral commutation is not available for the K178