

Catalog 8092/USA
Rotary Tables

High Precision

200RT Series

Features

- Highly repeatable indexing (12 arc sec.)
- Load capacities to 200 lbs
- 360 degrees continuous travel
- Performance tested worm gear drive
- Selectable table sizes and drive ratio
- Dual race angular contact support bearing

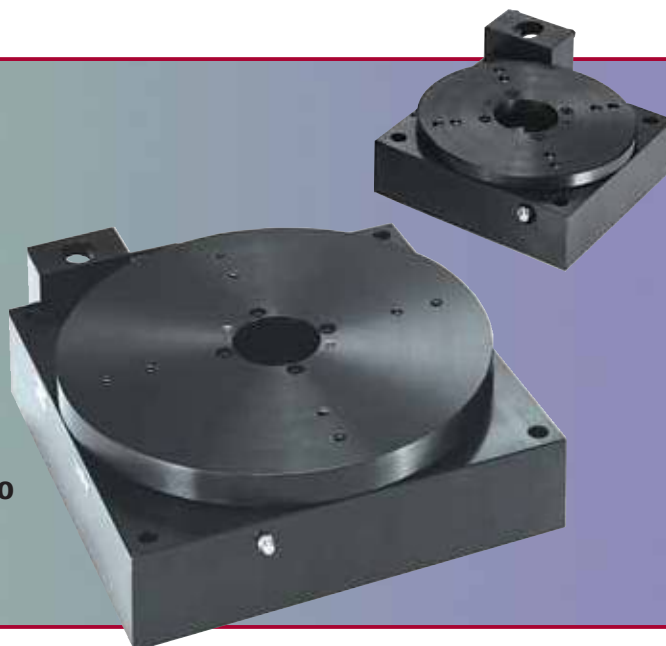

Quality Design and Construction

The 200RT Series Rotary Tables are designed for precise motor-driven rotary positioning and indexing. These tables are designed to function independently or in conjunction with linear tables used in the high precision and precision automation applications. Their low profile design minimizes stack height in multi-axis configurations and enables them to fit in many places where other motorized rotary devices cannot.

Models are available in 5, 6, 8, 10, or 12 inch diameters and are offered with four gear ratios making it convenient to match size, speed, and load requirements. They can be selected in either English or Metric mounting. They

are found in virtually all industries where intermittent part indexing, part scanning, skew adjustment, or precise angular alignment is required.

At the heart of these tables is a rugged main support bearing which is comprised of two preloaded angular contact bearing races. It is designed for high load capacity and smooth, flat rotary motion. The drive is a precision worm gear assembly which is preloaded to remove backlash. The top and base are constructed of high quality aluminum with an attractive black anodized finish. The top and bottom mounting surfaces are precision ground to assure flatness.

Options:

Motor Couplings

A wide range of coupling styles and bores are available to match motor requirements. Bellows-style couplings, offering the lowest windup are required for all precision grade tables, while the aluminum and stainless steel helix couplers offer good windup characteristics and high durability at a lower cost.

Motor Mounts

The motor mount is designed for an industry standard NEMA 23 motor flange and a maximum shaft length of 0.85".

Home Sensor

The Home sensor provides a fixed reference point to which the table can always return. This is a mechanical reed switch which is mounted the body of the rotary table and is activated by a magnet imbedded on the table top.

Rotary Encoders

High accuracy rotary encoders can be added for direct positional feedback of the table top position.

Seals

Custom designed sealed units are offered to prevent excessive wear or internal damage resulting from dust and contaminants.

Motors, Drives & Controls

Micro-step motors with drives are available for direct mounting to the rotary tables. Motion controllers can also be added to provide systems with seamless connectivity.

NOTE: Refer to www.parkermotion.com or contact a Parker applications engineer for additional detailed information pertaining to any of these options or accessories.

Catalog 8092/USA
 Rotary Tables

High Precision

200RT Series Characteristics

| Common Characteristics | Units | Precision | Standard |
|---|------------|--------------|---------------|
| Performance | | | |
| Positional Repeatability (unidirectional) | arc min | 0.2 | 0.5 |
| Duty Cycle | % | 50 | 50 |
| Table Runout (Max.) | in (µm) | ±0.001 (±25) | ±0.003 (±75) |
| Concentricity | in (µm) | ±0.001 (±25) | ±0.005 (±127) |
| Wobble | arc sec. | 30 | 60 |
| Input Velocity (Max.) | revs./sec. | 15 | 15 |

Travel Dependent Characteristics

| Table Diameter inches | Drive Ratio | Load Capacity lbs. (kgf) | Accuracy | | Output Torque in-lb (N-m) | Inertia 10 ⁻³ oz-in.-sec ² (10 ⁻⁶ kg-m-sec ²) | Input Breakaway Torque (max) oz-in (N-m) | Running Torque (max) oz-in (N-m) | Weight | |
|-----------------------|-------------|--------------------------|---------------|------|---------------------------|--|--|----------------------------------|-------------------|----------------|
| | | | Prec. arc min | Std. | | | | | Std. Top lb (kgf) | Total lb (kgf) |
| 5.0 | 180:1 | 25 (11) | 3 | 10 | 25 (2.8) | 0.14 (0.102) | 22 (0.16) | 20 (0.13) | 0.67 (0.3) | 6.0 (2.7) |
| 5.0 | 90:1 | 25 (11) | 3 | 10 | 25 (2.8) | 0.15 (0.112) | 22 (0.16) | 20 (0.13) | 0.67 (0.3) | 6.0 (2.7) |
| 5.0 | 36:1 | 25 (11) | 5 | 12 | 25 (2.8) | 0.24 (0.173) | 22 (0.16) | 20 (0.13) | 0.67 (0.3) | 6.0 (3.6) |
| 6.0 | 180:1 | 150 (68) | 3 | 10 | 40 (4.5) | 0.16 (0.112) | 22 (0.16) | 20 (0.13) | 0.91 (0.42) | 8.0 (2.7) |
| 6.0 | 90:1 | 150 (68) | 3 | 10 | 40 (4.5) | 0.20 (0.132) | 22 (0.16) | 20 (0.13) | 0.91 (0.42) | 8.0 (3.6) |
| 6.0 | 45:1 | 150 (68) | 5 | 12 | 40 (4.5) | 0.29 (0.204) | 22 (0.16) | 20 (0.13) | 0.91 (0.42) | 8.0 (3.6) |
| 8.0 | 180:1 | 150 (68) | 3 | 10 | 40 (4.5) | 0.24 (0.163) | 28 (0.19) | 25 (0.18) | 2.23 (1.01) | 15.0 (6.8) |
| 8.0 | 90:1 | 150 (68) | 3 | 10 | 40 (4.5) | 0.66 (0.459) | 28 (0.19) | 25 (0.18) | 2.23 (1.01) | 15.0 (6.8) |
| 8.0 | 36:1 | 150 (68) | 5 | 12 | 40 (4.5) | 0.90 (0.642) | 28 (0.19) | 25 (0.18) | 2.30 (1.05) | 15.0 (6.8) |
| 10.0 | 180:1 | 200 (90) | 3 | 10 | 190 (21.5) | 0.74 (0.530) | 33 (0.22) | 30 (0.21) | 5.26 (2.30) | 29.0 (13.1) |
| 10.0 | 90:1 | 200 (90) | 3 | 10 | 190 (21.5) | 1.02 (0.734) | 33 (0.22) | 30 (0.21) | 5.26 (2.30) | 29.0 (13.1) |
| 10.0 | 45:1 | 200 (90) | 5 | 12 | 190 (21.5) | 2.13 (1.53) | 33 (0.22) | 30 (0.21) | 5.26 (2.30) | 29.0 (13.1) |
| 12.0 | 180:1 | 200 (90) | 3 | 10 | 190 (21.5) | 0.99 (0.713) | 33 (0.22) | 30 (0.21) | 7.67 (3.49) | 32.0 (14.5) |
| 12.0 | 90:1 | 200 (90) | 3 | 10 | 190 (21.5) | 1.59 (1.12) | 33 (0.22) | 30 (0.21) | 7.67 (3.49) | 32.0 (14.5) |
| 12.0 | 45:1 | 200 (90) | 5 | 12 | 190 (21.5) | 3.83 (2.75) | 33 (0.22) | 30 (0.21) | 7.67 (3.49) | 32.0 (14.5) |

NOTE: For moment load calculations, refer to the technical section of Parker's web site www.parkermotion.com

Rotary Encoder Option:

High resolution, high accuracy ring encoders can be mounted to the base of the rotary table. The encoder is coupled directly to the rotary table top, providing positional feedback with no drive train errors. 314,880 or 3,148,800 post quadrature counts per revolution are available, and an encoder housing is included to enclose and protect the encoder.

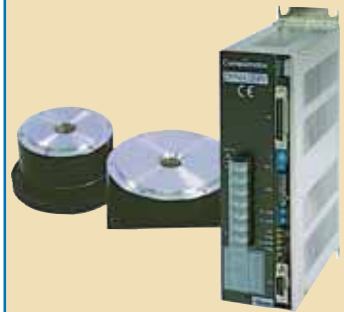

High Performance Direct Drive Rotary Tables

Parker's DM1004 direct drive brushless servo motor tables offer high throughput precision indexing. Refer to Section A of this catalog for complete information.

Catalog 8092/USA
 Rotary Tables

High Precision

200RT Series Dimensions inch (mm)

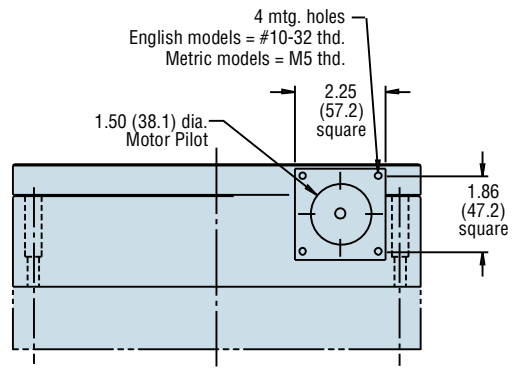
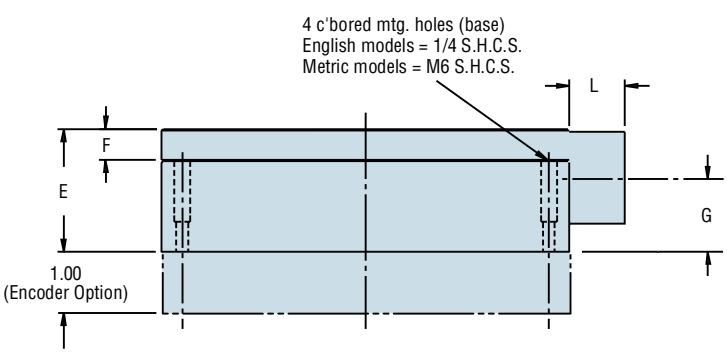
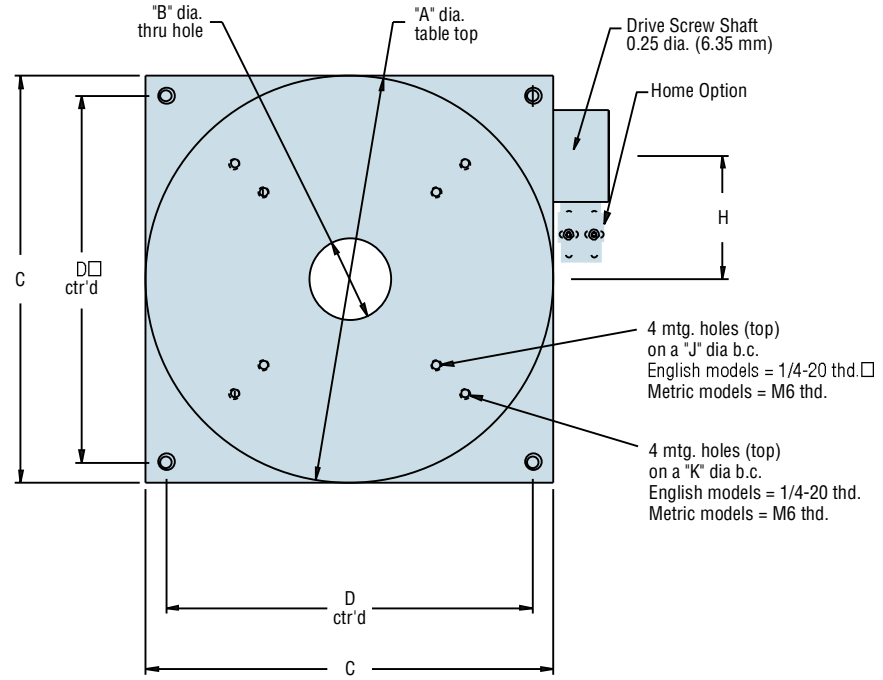

| | A | B | C | D | E | | F | | G | H | J | K | L |
|---------|-------|-------|-------|-----|-----------|-------------|-----------|-------------|------|------|-----|------|------|
| | | | | | Std. (T2) | Option (T3) | Std. (T2) | Option (T3) | | | | | |
| English | 5.0 | 1.0 | 5.0 | 4.0 | 1.8 | 2.42 | 0.38 | 1.00 | 1.11 | 1.66 | 3.0 | 4.0 | 1.38 |
| | 6.0 | 1.75 | 6.0 | 5.0 | 2.0 | 2.62 | 0.38 | 1.00 | 1.23 | 2.04 | 4.0 | 5.0 | 1.38 |
| | 8.0 | 1.75* | 8.0 | 6.0 | 2.5 | 3.00 | 0.50 | 1.00 | 1.57 | 2.04 | 4.0 | 6.0 | 1.38 |
| | 10.0 | 2.0 | 10.0 | 9.0 | 3.0 | 3.25 | 0.75 | 1.00 | 1.81 | 3.03 | 6.0 | 8.0 | 1.38 |
| | 12.0 | 2.0 | 10.0 | 9.0 | 3.0 | 3.25 | 0.75 | 1.00 | 1.81 | 3.03 | 8.0 | 10.0 | 2.38 |
| Metric | 127.0 | 25.4 | 127.0 | 100 | 46.0 | 61.5 | 9.6 | 25.0 | 28.1 | 42.1 | 75 | 100 | 35 |
| | 152.4 | 44.5 | 152.4 | 125 | 50.8 | 66.5 | 9.6 | 25.0 | 31.4 | 51.8 | 100 | 125 | 35 |
| | 203.2 | 44.5* | 203.2 | 175 | 63.5 | 76.2 | 12.7 | 25.0 | 39.8 | 51.8 | 100 | 150 | 35 |
| | 254.0 | 50.8 | 254.0 | 225 | 76.2 | 82.6 | 19.0 | 25.0 | 45.9 | 76.9 | 150 | 200 | 35 |
| | 304.8 | 50.8 | 254.0 | 225 | 76.2 | 82.6 | 19.0 | 25.0 | 45.9 | 76.9 | 200 | 250 | 60.4 |

*On the 8.0" (203,2) diameter table with 36:1 ratio, this dimension is 1.0" (25,4).

Catalog 8092/USA
 Rotary Tables

High Precision

200RT Series How to Order

Order Example

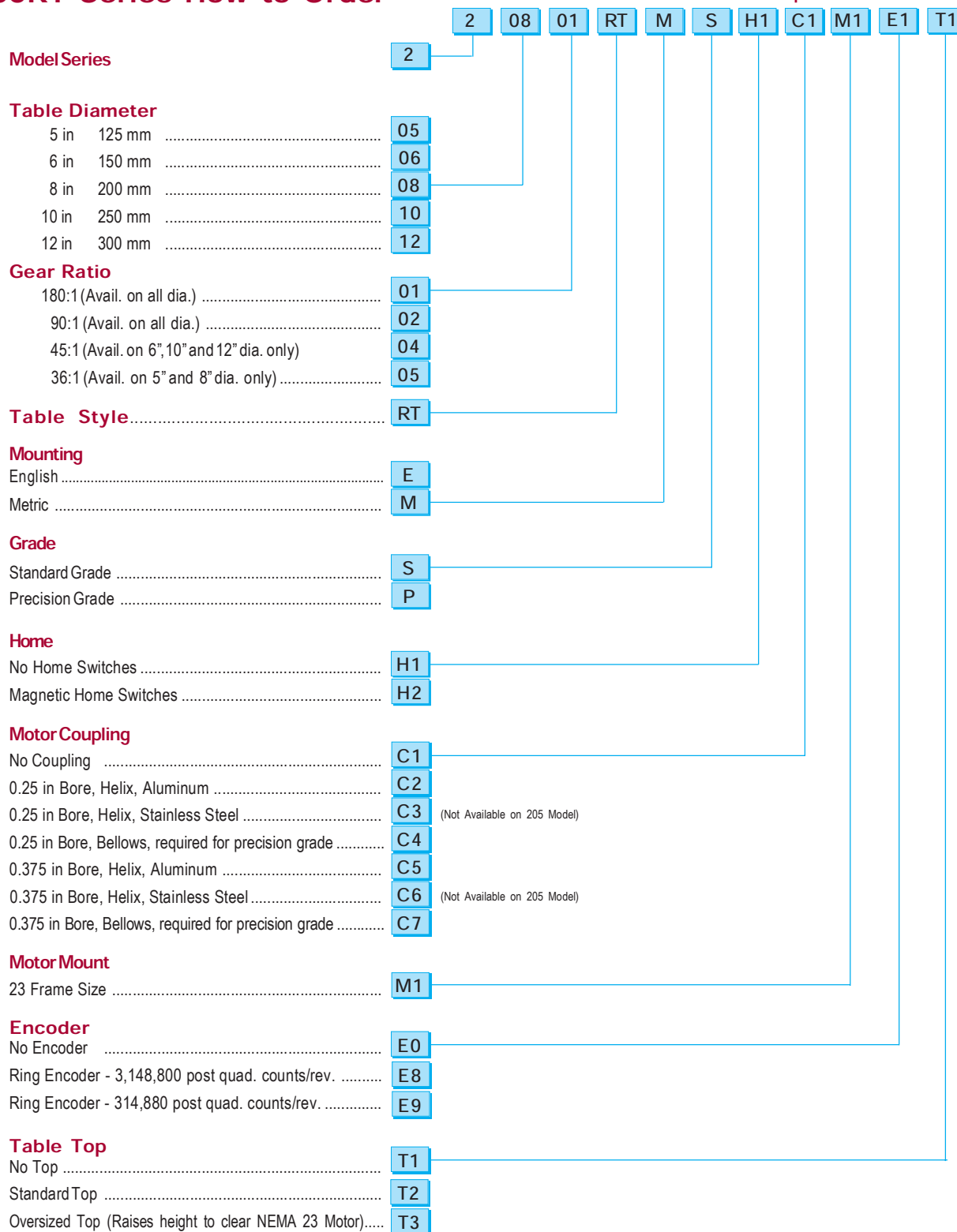

Screw Driven Tables